

C/S Acrovyn® Crash Rails and Bumper Guards



▲ College of Further Education (Germany)



▲ Herman Hospital (USA)

There is no better or simpler way of protecting walls from damage than using a C/S **Acrovyn®** Crash Rail.

Mounted at impact level, these crash rails range from 102mm in depth to 203mm.

All profiles use either aluminium retainers with integral bumper cushions or with simple mounting clips and snap-in cushions for economy.

SCR40

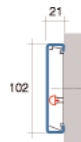

SCR50 and SCR50M

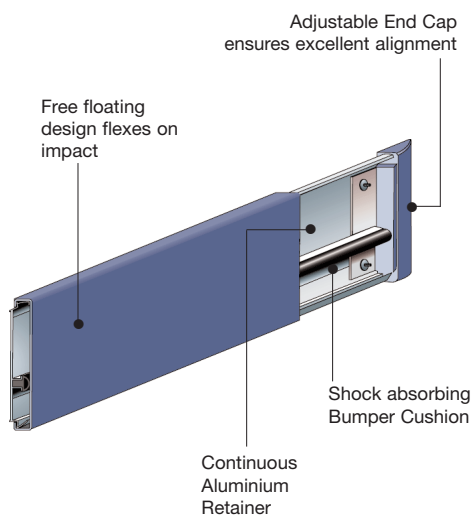
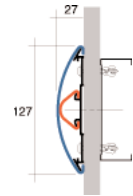

Fixings @ 400mm centres

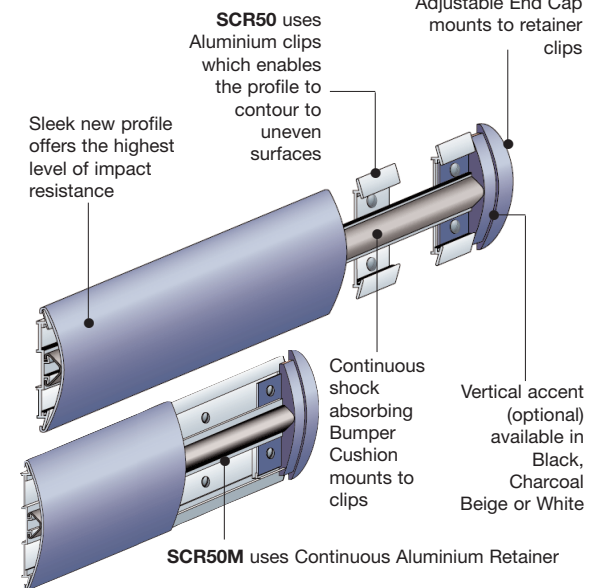

Fixings @ 400mm centres



Use the C/S Acrovyn® Colour Pull Out to view our Standard and Semi-standard Colour Chips



▲ National Cancer Centre (Singapore)



▲ Royal Mail Plymouth (UK)

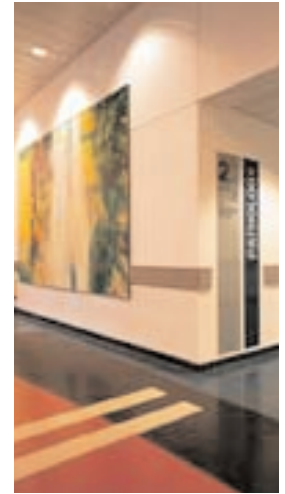

▲ Chelsea & Westminster Hospital (UK)

SCR150

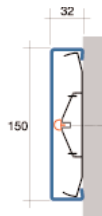

SCR64 and SCR64E

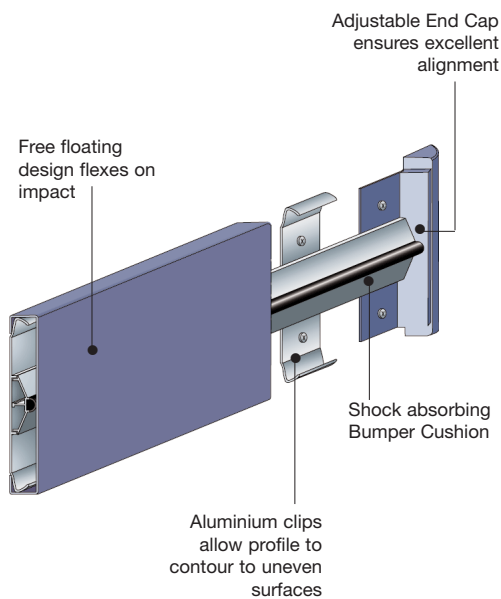
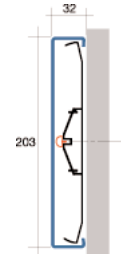

Fixings @ 600mm centres

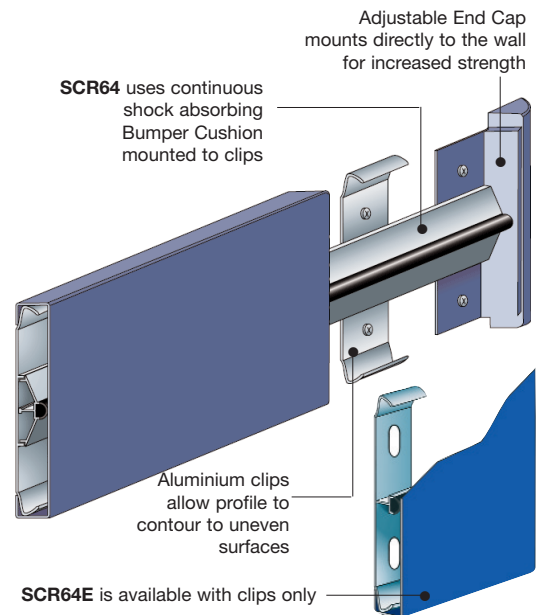

Fixings @ 600mm centres



Use the C/S Acrovyn® Colour Chart Pull Out to view our Standard and Semi-standard Colour Chips

C/S Acrovyn® Crash Rails and Bumper Guards



▲ Health Centre (Germany)

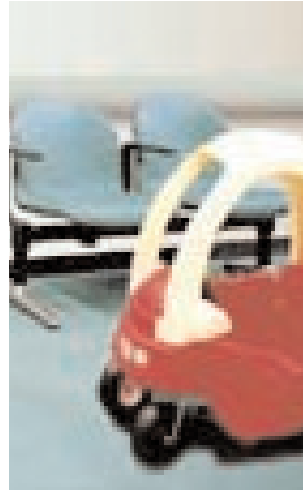

▲ Health Centre (Germany) - Detail

C/S Acrovyn® have added two new profiles to its range of Crash Rails, **SCR-50** and **SCR-80**.

Both profiles not only look great but are capable of withstanding the roughest of treatments that can be inflicted by mobile equipment.

Now wall protection can be visually stunning as well as functional.

SCR80 and SCR80M

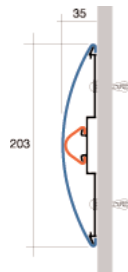

SCR90

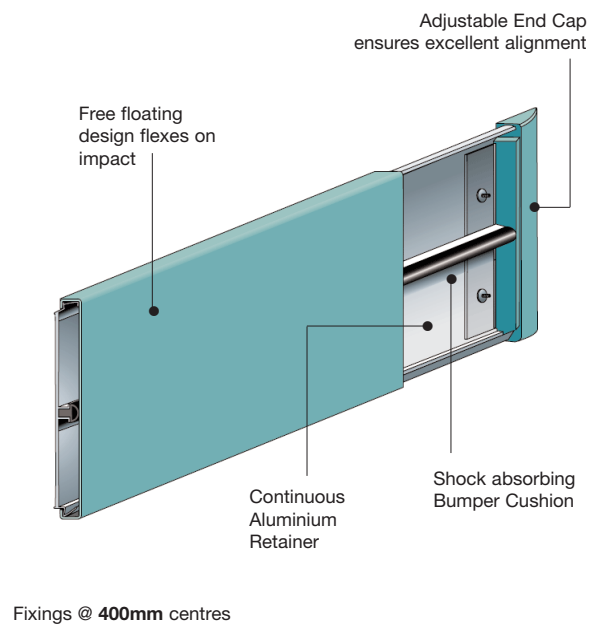
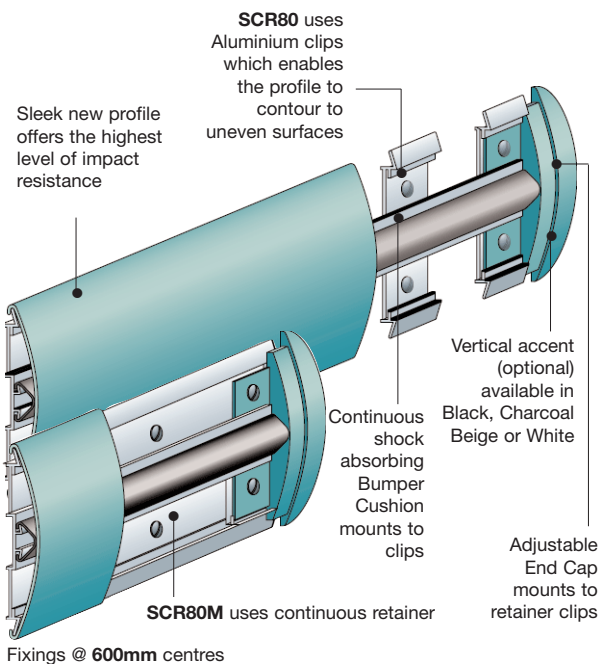
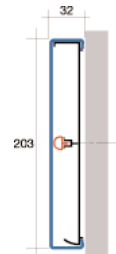

Use the C/S Acrovyn® Colour Chart Pull Out to view our **Standard** and **Semi-standard Colour Chips**



▲ Worcestershire Royal Hospital PFI (UK)



▲ Scripps Hospital (USA)

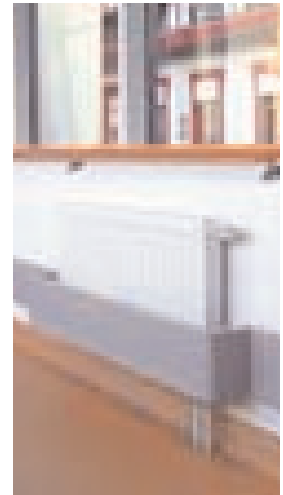

▲ Primary School (UK)

HCR64

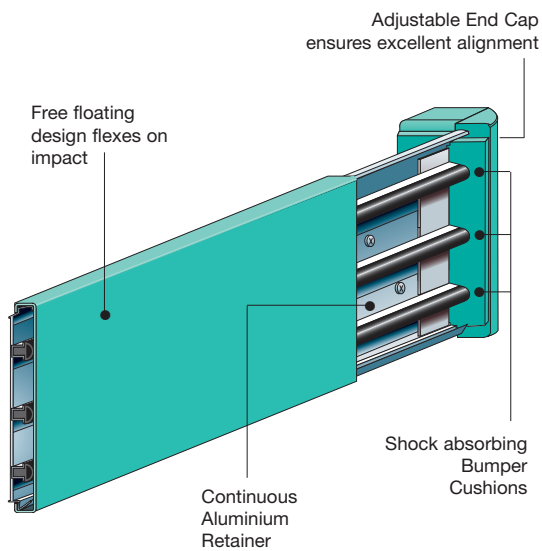
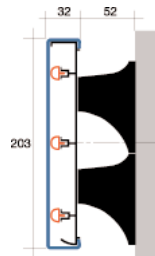

Fixings @ 400mm centres



Use the C/S Acrovyn® Colour Chart Pull Out to view our Standard and Semi-standard Colour Chips

Crash Rail Mounting Options

Surface Mounting Style

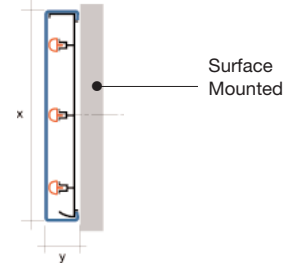

Bumper Mounting Style

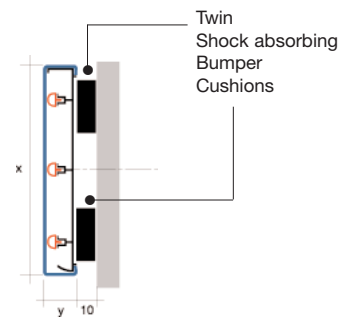

Extended Mounting Style

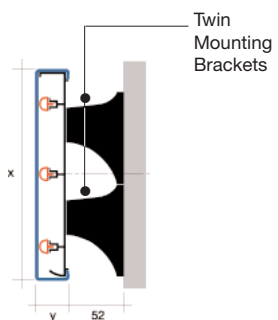

C/S Acrovyn® Crash Rails and Bumper Guards



▲ County Hospital Hereford (UK)



▲ Sister Thea Bowman Health Centre (USA)

C/S **Acrovyn**® Bumper Guards and Trolley Plate add to the portfolio of wall protection on offer to the specifier.

They provide an effective alternative to the Crash Rail, especially in areas that are less heavily trafficked.

FR270

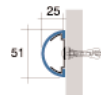

BG30

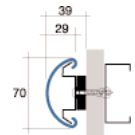

Adjustable End Cap and outside corners available

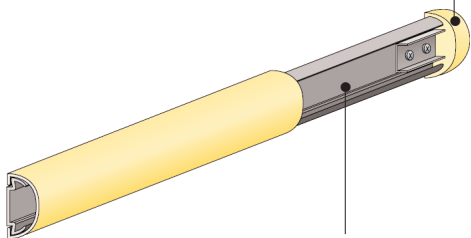

High strength retainer made from 100% recycled Acrovyn

Fixings @ 800mm centres

End Cap ensures excellent alignment

Small Bullnose for "low profile" protection

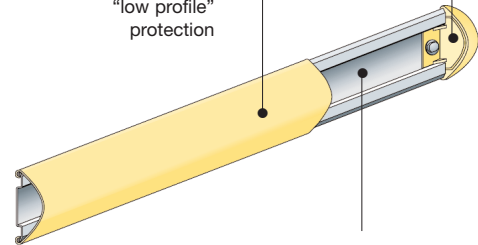

Aluminium retainer design allows guard to flex on impact

Fixings @ 400mm centres



Use the C/S Acrovyn® Colour Chart Pull Out to view our Standard and Semi-standard Colour Chips



▲ University Hospital of North Durham (UK)



▲ Hairmyres Hospital East Kilbride (Scotland)



▲ Wythenshawe Hospital (UK)

BG10

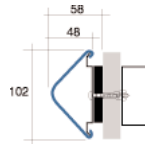

Trolley Plate

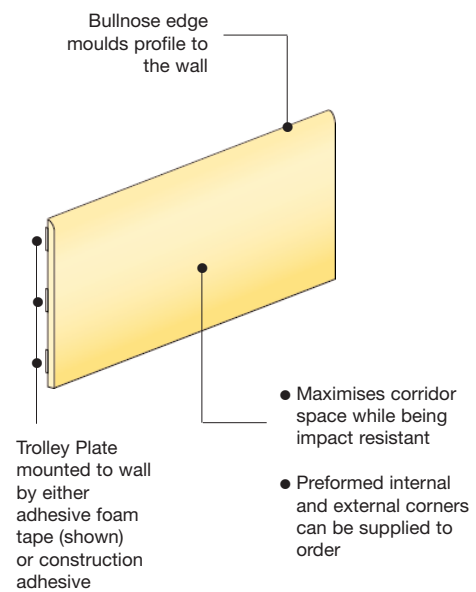
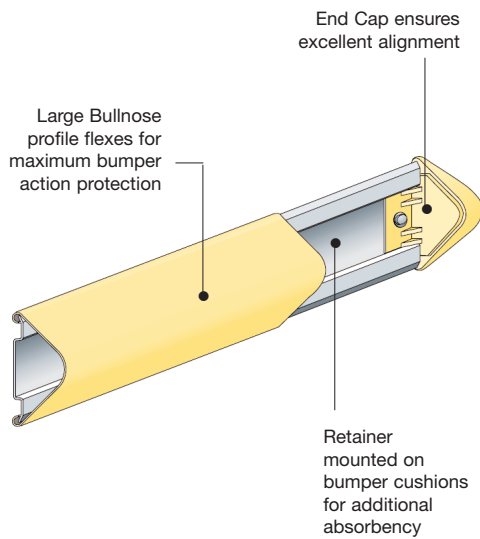

Fixings @ 400mm centres



Use the C/S Acrovyn® Colour Chart Pull Out to view our Standard and Semi-standard Colour Chips

C/S Acrovyn® Crash Rails and Bumper Guards



▲ Royal Mail Canteen (UK)



▲ HMS Drake Plymouth (UK)

C/S Acrovyn® Stainless Steel Crash Rails give the specifier considerable options for size, profile and finish. They are available in dull or polished finish, and in a variety of rail depths.

These profiles are particularly suited to areas that require both protection and a hygienic finish such as canteens, kitchens and food processing areas, pharmaceutical and hospital laboratories.

CRS100, CRS150 and CRS200

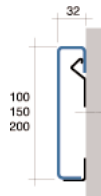

CRC150

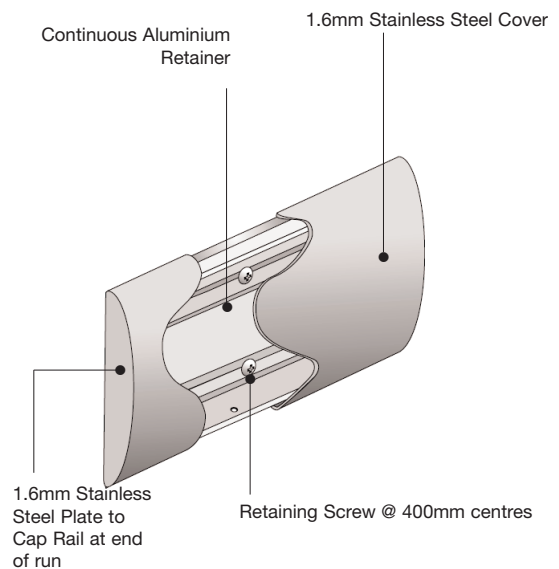
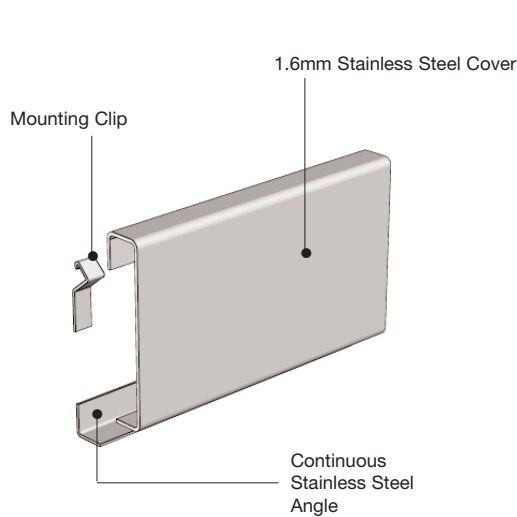
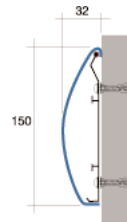
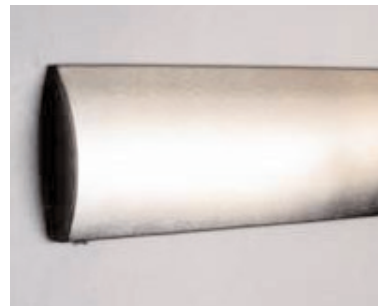

- Stainless Steel and Retail



▲ HMS Drake Plymouth (UK)



▲ Chiltern Finance Aylesbury (UK)

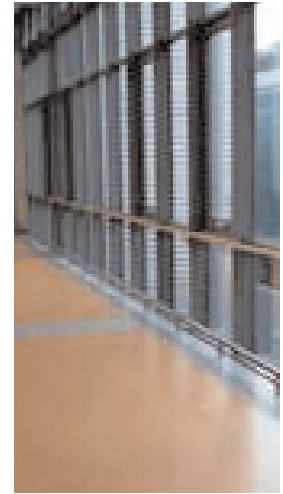

▲ Royal Victoria Hospital Belfast (Northern Ireland)

LLRSS

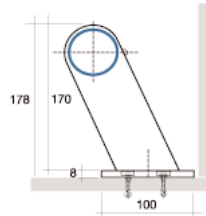

LLR

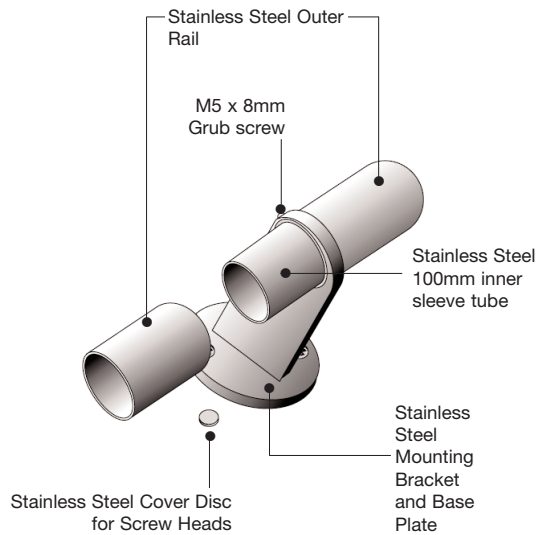
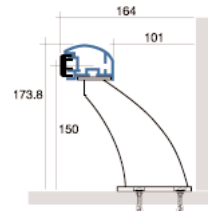

Low Level Rail 90° Corner can be powder coated to provide a matching or contrasting colour

Low Level Rail can be anodised or powder coated and is available in a range of colours

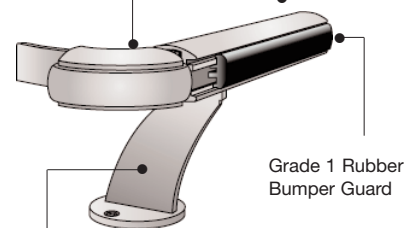

Steel Mounting Bracket and Base Plate can be powder coated to provide a matching or contrasting colour

C/S Acrovyn® Crash Rails and Bumper Guards



▲ Printcraft, Leeds



▲ Chelsea and Westminster Hospital

C/S **Acrovyn**® Rubber Crash rails and Bumpers are the ideal surface protection for areas subject to probable damage from vehicular traffic, whether inside or outside the building.

The extruded rubber profiles have excellent shock absorbing and weathering properties and are suitable for fixing onto virtually any surface including concrete, steel, masonry and timber.

60B

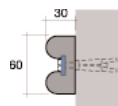
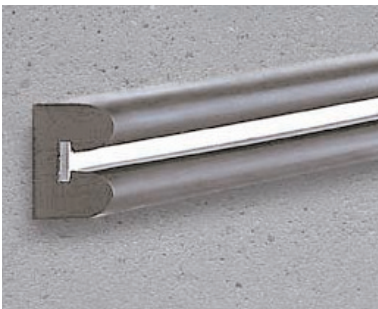

75D and 100D

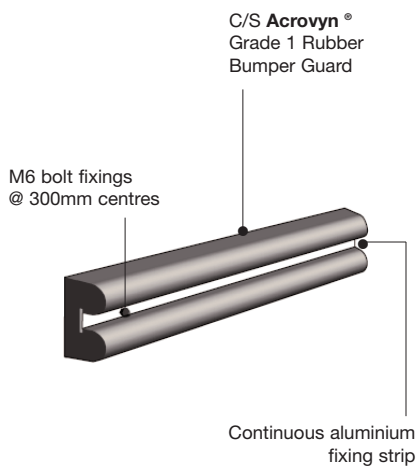
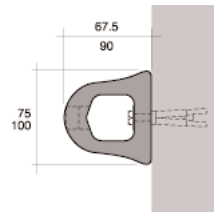

Fixings @ 300mm centres

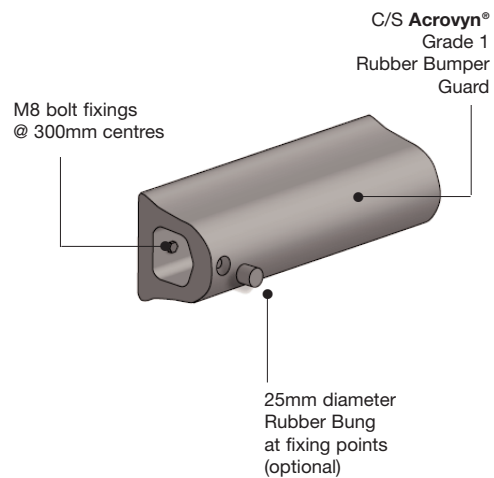

Fixings @ 300mm centres



▲ Federal Bank (Austria)



▲ Retail storage Area



▲ The Ark at Hammersmith, London (UK)

150W20

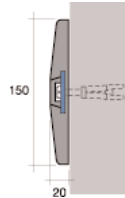

200W30 and 200W50

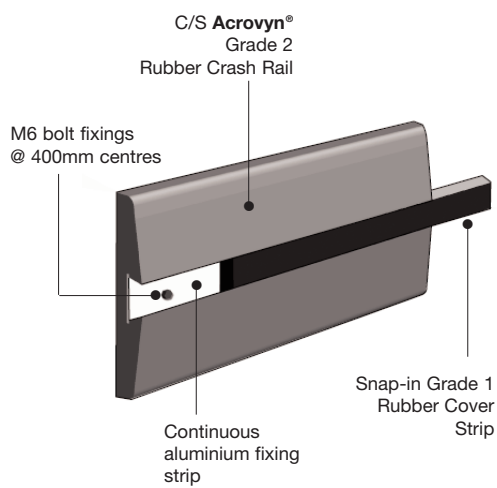
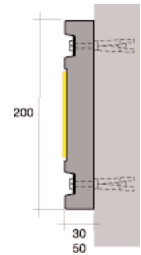
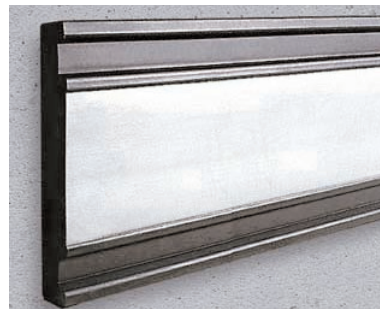

Fixings @ 400mm centres

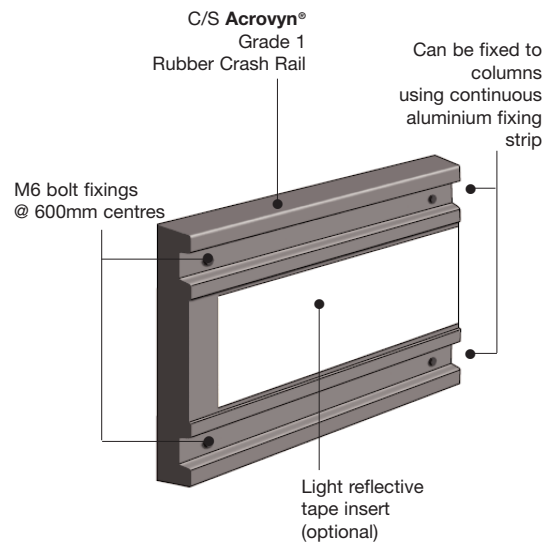

Fixings @ 600mm centres