

C/S Allway[®] Expansion Joint Covers



C/S Allway® Expansion Joint Covers



World Class Solution from a World Class Company.

The design of this magnificent building involved two International Architects, KPF the base build and client fit out by Gensler. The building comprises a 31-storey tower, rising alongside a 5-storey podium.

With different settlement rates for each building, and the tower having a smaller footprint, accommodation of three dimensional movements, where both buildings meet, was required.

Gensler also required the selected EJC to be capable of accepting sections of the same 40mm thick polished stone used for the floor finishes, into which the EJC would be incorporated. C/S were invited by Gensler to provide a suitable EJC solution.

After exhaustive discussions, one model was possibly identified whose performance appeared to meet the design and aesthetic requirements. Therefore, to prove the performance capabilities, it was decided to commission the C/S computerised test rig and subject the EJC to the full criteria required, which showed the joint to perform with 100% efficiency.

This is just another example of the worldwide responsible commitment, and technical capability, the C/S Group offers, to ensure that our EJCs accommodate building movement both aesthetically and technically.

C/S Allway – expansion joint covers you can trust.



Construction Specialties manufacture the most comprehensive range of expansion joint cover assemblies in the world, to accommodate every conceivable type of building movement. These systems range from modest cover plates to the most sophisticated fire rated joint cover assemblies available.

Selection Criteria

Key parameters for consideration in selection of movement joint covers:

- width of available structural gap/joint width
- range of movement/direction
- amount of movement
- finishes to be accommodated in joints (floor finish/wall finish)
- environmental considerations
- building's usage at EJC location re. loadings
- necessity for vapour barrier
- necessity for fire barrier

Technical Support

For assistance with technical and installation details, please contact our technical department.

For testing of complicated movement parameters our R&D facility is accessible.

C/S GROUP Data Sheet:
November 2003

GFT-100/50 Flush Seal Thinline Floor to Floor Joint Cover	25mm	±5mm	±3mm	±1,5mm
	Nominal	Horizontal	Vertical	Lateral
		Movement Capacity		

GFTW-100/50 Flush Seal Thinline Floor to Wall Joint Cover	25mm	±5mm	±3mm	±1,5mm
	Nominal	Horizontal	Vertical	Lateral
		Movement Capacity		

Allway® Expansion Joint Cover Systems

Construction Specialties (UK) Ltd
 Conspic House
 St Andrews Way
 Bicester Road
 Aylesbury
 Buckinghamshire HP19 8AF
 England

Tel: +44 (0)1296 399700
 Fax: +44 (0)1296 399444
 e-mail: info@c-sgroup.co.uk
 Internet: www.c-sgroup.co.uk

All dimensions in millimetres unless otherwise stated.
Do not scale from the drawing. If in doubt ask!

CAD details are available for the full range of C/S Allway expansion joint covers. Please e-mail your request to info@c-sgroup.co.uk or telephone +44 (0)1296 6110000.

Project Portfolio 4-5
Selection Chart 6-7
Flush Seal™ Standard Floor 8-13 Wall 24-27
Heavy Duty Floor 14-15
All Metal™ Floor 16-17 Wall 28
Large Span Floor 18-21 Wall 29
Parking Deck Covers 22-23
Cover Strips & Plugging Sections 30-31
Fire Barriers 32-33
Technical Information 34

C/S Allway® Expansion Joint Covers



1. UCLA Anderson School - Los Angeles, USA
2. Printworks - Manchester, UK
3. Chek Lap Kok Airport - Hong Kong, China
4. JFK International Airport - New York, USA
5. National Physical Laboratory - Teddington, UK
6. Canary Wharf - London, UK

7. Edinburgh Royal Infirmary - Edinburgh, UK
8. Bank Headquarters - London, UK
9. Stansted Airport - Stansted, UK
10. San Francisco International Airport - San Francisco, USA
11. Cribbs Causeway Shopping Centre - Bristol, UK

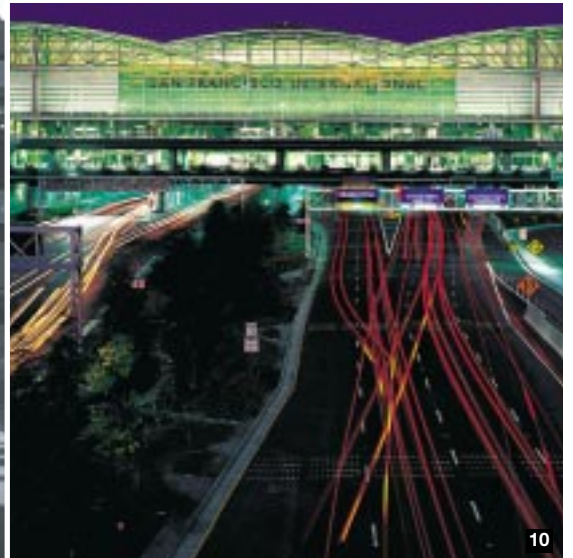

C/S Allway® Expansion Joint Covers Selection Guide

		Model	Page	Type of Joint	Joint Width
Floor Joint Covers	Thinline Flush Seal™	GFS(W)	P. 8-9	surface mounted	Up to 50mm
		GFPS(W)	P. 8-9	surface mounted	Up to 50mm
		GFST(W)	P. 8-9	surface mounted	Up to 50mm
		GFT(W)	P. 10-11	recess mounted	Up to 50mm
		GFTB(W)	P. 10-11	recess mounted	Up to 50mm
	Heavy Duty Seal	HO(P/PD)	P. 14-15	recess mounted	Up to 65mm
		RLO(P/PD)	P. 14-15	surface mounted	Up to 70mm
	Twinline Flush Seal™	GFP(W)	P. 12-13	recess mounted	Up to 100mm
		GFR(W)	P. 12-13	recess mounted	Up to 100mm
		GFRD(W)	P. 12-13	recess mounted	Up to 100mm
	Twinline Flush Seal™ Heavy Duty	GFP(W)-HD	P. 14-15	recess mounted	Up to 100mm
	All Metal™	ALS(W/M)	P. 16-17	recess mounted	Up to 100mm
		ALX(W)	P. 16-17	recess mounted	Up to 50mm
		AL(W)-HD(C)	P. 16-17	recess mounted	Up to 100mm
		ALM-(HD)	P. 16-17	recess mounted	Up to 100mm
	Twinline Large Span	SSR(W)	P. 18-19	recess mounted	Up to 250mm
		SGR(W)	P. 18-19	recess mounted	Up to 250mm
		SGP(W)	P. 18-19	recess mounted	Up to 250mm
	All Metal™ Large Span	SJP(W)	P. 20-21	recess mounted	Up to 250mm
		SJPF(W)	P. 20-21	recess mounted	Up to 150mm
		SJ(W)-HD	P. 20-21	recess mounted	Up to 200mm
	Parking Joints	CSS	P. 22-23	recess mounted	Up to 50mm
		ZB	P. 22-23	recess mounted	Up to 100mm
KB(W)		P. 22-23	recess mounted	Up to 200mm	
PTC(W)		P. 22-23	recess mounted	Up to 250mm	
Wall/Ceiling Joint Covers	Thinline Flush Seal™	FGFS(C)	P. 24-25	surface mounted	Up to 50mm
		FWF(C)	P. 24-25	recess mounted	Up to 50mm
		FWFP(C)	P. 24-25	recess mounted	Up to 50mm
		FWS(C)	P. 26-27	recess mounted	Up to 100mm
		FCS(C)	P. 26-27	recess mounted	Up to 100mm
		HC	P. 26-27	recess mounted	Up to 100mm
	All Metal™	SM(C)	P. 28	surface mounted	Up to 50mm
	Twinline Large Span	SGW(C)	P. 29	recess mounted	Up to 250mm
	Large Span	SC	P. 29	recess mounted	Up to 250mm
Plugging Sections		JD	P. 30	recess mounted	Up to 66mm
Rigid Joint Strips for Walls / Floors		W	P. 31	surface mounted	Up to 100mm
Fire Barriers		Reflex, Multiflex	p. 32-33	recess mounted	Up to 250mm

Movement Direction			% of +/- Thermal Horizontal Movement	Type of Use	Matching Floor/Wall	Typical Loading
Horizontal	Vertical	Lateral				
✓	✓*	✓*	Up to 20%	Interior	P. 24-25	227Kg point load
✓	✓*	✓*	Up to 20%	Interior	P. 24-25	227Kg point load
✓	✓	✓	Up to 20%	Interior	P. 24-25	227Kg point load
✓	✓	✓	Up to 20%	Interior	P. 24-25	227Kg point load
✓	✓	✓	Up to 20%	Interior	N/A	227Kg point load
✓			Up to 20%	Interior/Exterior	N/A	907Kg point load
✓			Up to 18%	Interior/Exterior	N/A	907Kg point load
✓	✓**	✓	Up to 50%	Interior	N/A	227Kg point load
✓	✓**	✓	Up to 50%	Interior	N/A	227Kg point load
✓		✓	Up to 50%	Interior	N/A	227Kg point load
✓	✓**	✓	Up to 50%	Interior/Exterior	N/A	907Kg point load
✓	✓	✓	Up to 100%	Interior	N/A	227Kg point load
✓		✓	Up to 80%	Interior/Exterior	N/A	227Kg point load
✓	✓	✓	Up to 100%	Interior/Exterior	N/A	907Kg point load
✓	✓	✓	Up to 50%	Interior/Exterior	N/A	907Kg point load
✓†		✓	Up to 20%	Interior/Exterior	N/A	227Kg point load
✓†	✓**	✓	Up to 25%	Interior/Exterior	P. 29	227Kg point load
✓†	✓**	✓	Up to 25%	Interior/Exterior	P. 29	227Kg point load
✓		✓	Up to 50%	Interior/Exterior	N/A	227Kg point load
✓		✓	Up to 24%	Interior/Exterior	N/A	227Kg point load
✓		✓	Up to 25%	Interior/Exterior	N/A	907Kg point load
✓	✓		Up to 40%	Exterior	N/A	vehicular traffic
✓			Up to 50%	Exterior	N/A	vehicular traffic
✓	✓	✓	Up to 50%	Exterior	N/A	907Kg point load
✓†	✓	✓	Up to 33%	Exterior	N/A	907Kg point load
✓	✓*	✓*	Up to 20%	Interior	P. 8-9	N/A
✓	✓	✓*	Up to 20%	Interior	P. 8-9 or 10-11	N/A
✓	✓	✓*	Up to 20%	Interior	P. 10-11	N/A
✓	✓	✓	Up to 75%	Interior	N/A	N/A
✓	✓	✓	Up to 75%	Interior	N/A	N/A
✓	✓		Up to 100%	Interior	N/A	N/A
✓			Up to 64%	Interior	N/A	N/A
✓†		✓	Up to 20%	Interior	P. 18-19	N/A
✓			Up to 90%	Exterior	N/A	N/A
✓			Up to 20%	Interior/Exterior	N/A	N/A
✓			N/A	Interior	P. 31	227Kg point load (Floors only)
To suit specified EJC			To suit specified EJC	Interior	N/A	N/A

* Denotes limited models only.

** Denotes floor to floor joint covers only.

† Denotes larger seismic movement capacity, for details contact our Technical Department on 01296 611000

C/S Allway® Expansion Joint Covers

Thinline Flush Seal™ Floor Joint Covers (Interior Joints to 50mm)

Series of surface mounted floor joint covers incorporating a dual durometer thermoplastic rubber gasket.

- Replaceable gasket
- Smooth, easy clean surface
- No blockout required

GFS

The easy to install surface mounted floor joint covers

GFWS

The floor to wall versions of GFS

GFPS

An alternative to GFS joint covers where the exposed aluminium frames are recessed to take a 5mm thick carpet or vinyl floor finish

GFPSW

The floor to wall version of GFPS

GFST

An alternative to GFPS joint covers where the carpet or vinyl floor finish butts up to the edge of the aluminium frames

GFSTW

The floor to wall version of GFST

Colours

Aluminium Sections - standard finish is clear anodise except for GFPS(W) models, where side frame is supplied mill finished. Other colours can be supplied subject to minimum quantity.

C/S TPR Gaskets – supplied in rolls up to 30 metres in length, in Black, White, Grey and Greige as standard (see general information page 34). Other colours can be made available, subject to quantity.

GFS-80. Thinline Flush Seal™ floor-to-floor joint cover.

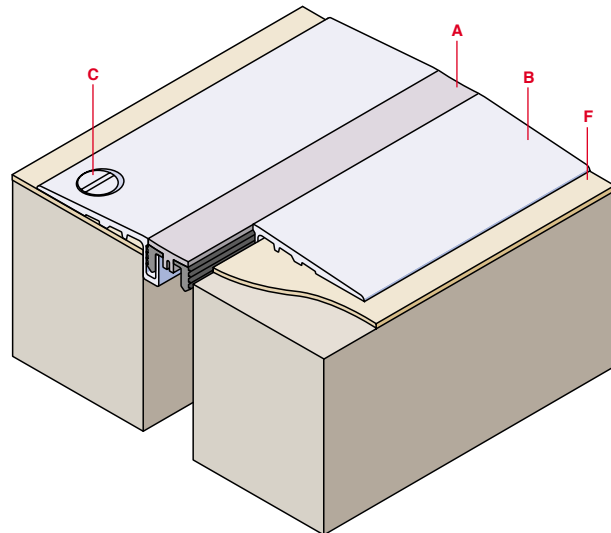

Product Data

Model	Number	Joint Width (mm)	Exposed Surface (mm)	Thermal Movement Capacity ±(mm)			Complementary Wall/Ceiling Joint Covers
				Horizontal	Vertical	Lateral	
GFS	80	20.0	105.0	±3.0	0	0	FGFS-80
	100	25.0	111.0	±5.0	±3.0	±1.5	FGFS-100
	200	50.0	129.0	±10.0	±3.0*	±3.0	FGFS-200
GFWS	80	20.0	62.0	±3.0	0	0	FGFSC-80
	100	25.0	67.0	±5.0	±3.0	±1.5	FGFSC-100
	200	50.0	90.0	±10.0	±3.0*	±3.0	FGFSC-200
GFPS	80	20.0	23.0	±3.0	0	0	N/A
	100	25.0	30.0	±5.0	±3.0	±1.5	FWF-100
	200	50.0	48.0	±10.0	±3.0*	±3.0	FWF-200
GFPSW	80	20.0	22.0	±3.0	0	0	N/A
	100	25.0	28.0	±5.0	±3.0	±1.5	FWFC-100
	200	50.0	48.0	±10.0	±3.0*	±3.0	FWFC-200
GFST	100	25.0	111.0	±5.0	±3.0	±1.5	FGFS-100
	200	50.0	130.0	±10.0	±3.0*	±3.0	FGFS-200
GFSTW	100	25.0	68.0	±5.0	±3.0	±1.5	FGFSC-100
	200	50.0	90.0	±10.0	±3.0*	±3.0	FGFSC-200

* No vertical movement when joint in compression.

GFPS-100. Thinline Flush Seal™ floor-to-floor joint cover.

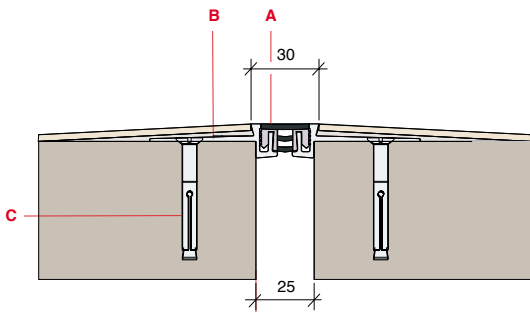

GFST-200. Thinline Flush Seal™ floor-to-floor joint cover.

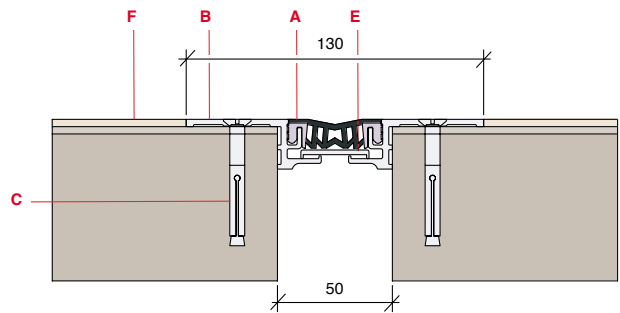

GFSW-80. Thinline Flush Seal™ floor-to-wall joint cover.

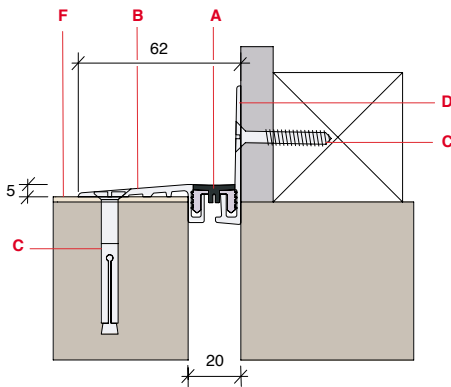

GFSTW-200. Thinline Flush Seal™ floor-to-wall joint cover.

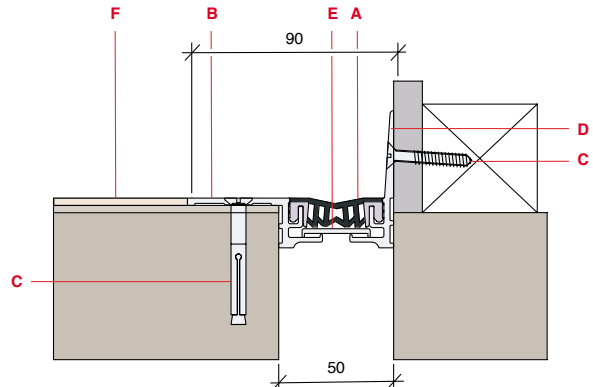

Key for diagrams

- A. C/S TPR gasket
- B. Continuous extruded aluminium side frame with clear anodised finish (mill finished for GFPS(W) models)
- C. Fixing to suit substrate (by others), please refer to Product Data Sheet
- D. Continuous extruded aluminium wall frame with clear anodised finish
- E. Continuous extruded aluminium centre plate (mill finished)
- F. Floor finish

Specification Style

Supply and install 120 metres C/S Allway Thinline Flush Seal™ series floor to floor expansion joint cover, model ref: GFST-200, complete with Grey C/S TPR gasket.

Optional Clauses:

- i) Reflex Fire Barrier, to suit 50mm joint width and providing minimum 2 hours integrity and insulation when installed in accordance with manufacturer's instructions.
- ii) Vapour Barrier/Water Stop to suit 50mm joint width.

All manufactured and supplied by Construction Specialties (UK) Ltd, Conspic House, St Andrews Way, Bicester Road, Aylesbury, Bucks HP19 8AF
Tel: 01296 611000

C/S Allway® Expansion Joint Covers

Thinline Flush Seal™ Floor Joint Covers (Interior Joints to 50mm)

Series of 25mm and 50mm wide recess mounted floor joint covers incorporating a dual durometer thermoplastic rubber gasket, available in various frame depths

- Flush floor finish
- Replaceable gasket
- Smooth, easy clean surface
- Multi-directional movement

GFT

The standard embedded joint covers for floor joints up to 50mm wide, available in four frame depths. Can be fitted flush to the floor screed or left proud to butt up to a carpet or vinyl finish

GFTW

The floor to wall versions of GFT

GFTB

As the GFT but with a brass frame cap edging the gasket, available with 51mm deep frame only

GFTBW

The floor to wall version of GFTB

Colours

Aluminium Sections - mill finished as standard, except for exposed wall frames, which are supplied with clear anodised finish. Other colours can be supplied subject to minimum quantity.

C/S TPR Gaskets – supplied in rolls up to 30 metres in length, in Black, White, Grey and Greige as standard (see general information page 34). Other colours can be made available, subject to quantity.

GFT-200/20. Thinline Flush Seal™ floor-to-floor joint cover.

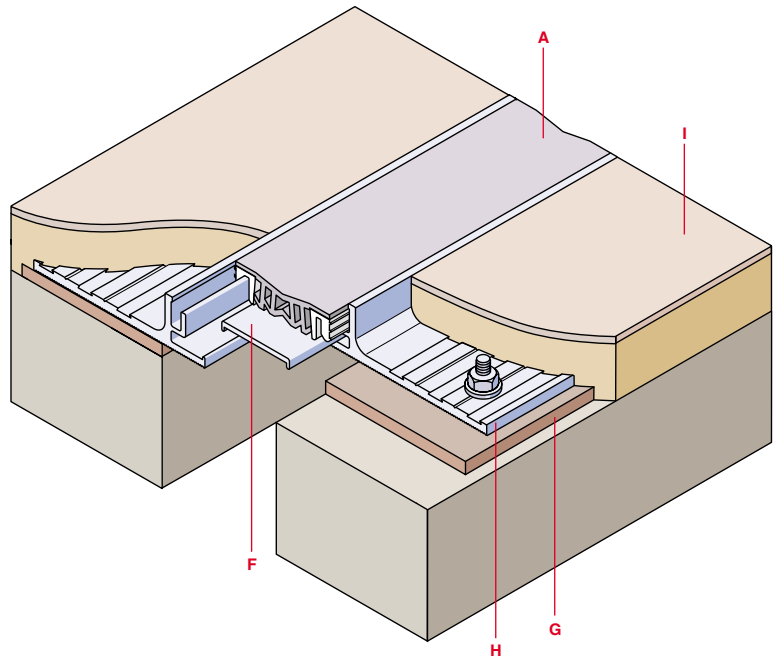

Product Data

Model	Number	Joint Width (mm)	Frame Depth (mm)	Exposed Surface (mm)	Thermal Movement Capacity \pm (mm)			Complementary Wall/Ceiling Joint Covers
					Horizontal	Vertical	Lateral	
GFT	100/20	25.0	20.0	28.0	± 5.0	± 3.0	± 1.5	FWF-100 or FWFP-100
	100/38	25.0	38.0	32.0	± 5.0	± 3.0	± 1.5	FWF-100 or FWFP-100
	100/50	25.0	51.0	32.0	± 5.0	± 3.0	± 1.5	FWF-100 or FWFP-100
	100/75	25.0	75.0	32.0	± 5.0	± 3.0	± 1.5	FWF-100 or FWFP-100
	200/20	50.0	20.0	48.0	± 10.0	$\pm 3.0^*$	± 3.0	FWF-200 or FWFP-200
	200/38	50.0	38.0	48.0	± 10.0	$\pm 3.0^*$	± 3.0	FWF-200 or FWFP-200
	200/50	50.0	51.0	48.0	± 10.0	$\pm 3.0^*$	± 3.0	FWF-200 or FWFP-200
GFTW	100/20	25.0	20.0	28.0	± 5.0	± 3.0	± 1.5	FWFC-100 or FWFCPC-100
	100/38	25.0	38.0	29.0	± 5.0	± 3.0	± 1.5	FWFC-100 or FWFCPC-100
	100/50	25.0	51.0	29.0	± 5.0	± 3.0	± 1.5	FWFC-100 or FWFCPC-100
	100/75	25.0	75.0	29.0	± 5.0	± 3.0	± 1.5	FWFC-100 or FWFCPC-100
	200/20	50.0	20.0	48.0	± 10.0	$\pm 3.0^*$	± 3.0	FWFC-200 or FWFCPC-200
	200/38	50.0	38.0	48.0	± 10.0	$\pm 3.0^*$	± 3.0	FWFC-200 or FWFCPC-200
	200/50	50.0	51.0	48.0	± 10.0	$\pm 3.0^*$	± 3.0	FWFC-200 or FWFCPC-200
GFTB	100/50	25.0	51.0	34.0	± 5.0	± 3.0	± 1.5	N/A
	200/50	50.0	51.0	54.0	± 10.0	$\pm 3.0^*$	± 3.0	N/A
	200/50	50.0	51.0	52.0	± 10.0	$\pm 3.0^*$	± 3.0	N/A
GFTBW	100/50	25.0	51.0	30.0	± 5.0	± 3.0	± 1.5	N/A
	200/50	50.0	51.0	52.0	± 10.0	$\pm 3.0^*$	± 3.0	N/A

* No vertical movement when joint in compression.

GFTB-100/50. Thinline Flush Seal™ floor-to-floor joint cover.

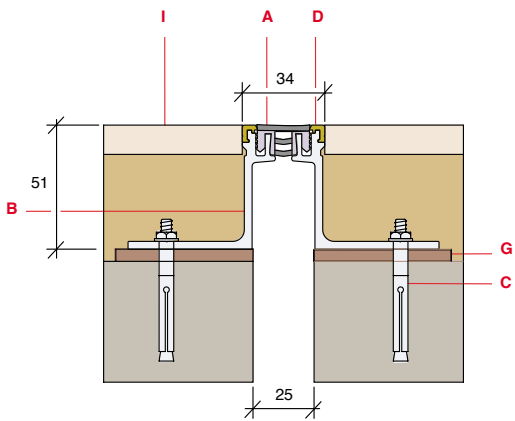

GFT-200/50. Thinline Flush Seal™ floor-to-floor joint cover.

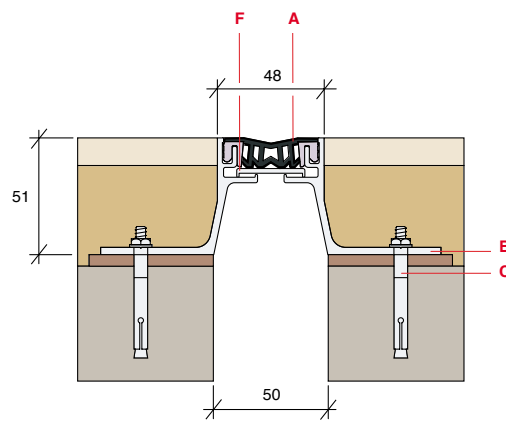

GFTBW-100/50. Thinline Flush Seal™ floor-to-wall joint cover.

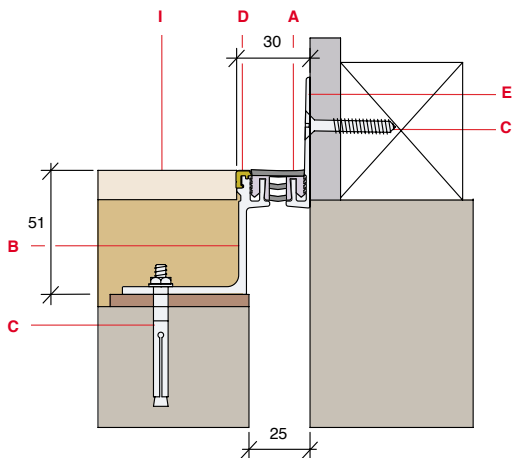

GFTW-200/50. Thinline Flush Seal™ floor-to-wall joint cover.

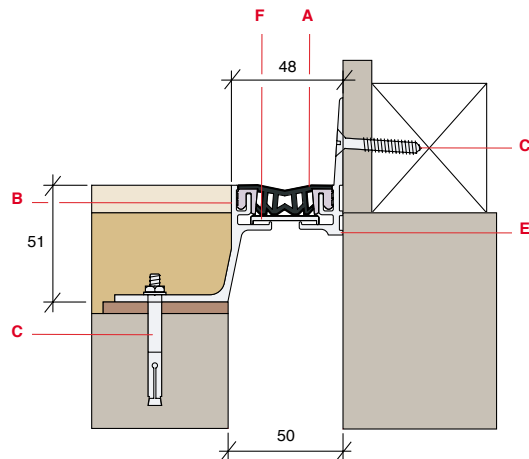

Key for diagrams

- A. C/S TPR gasket
- B. Continuous extruded aluminium side frame (mill finished)
- C. Fixing to suit substrate (by others), please refer to Product Data Sheet
- D. Brass capping section
- E. Continuous extruded aluminium wall frame with clear anodised finish
- F. Continuous extruded aluminium centre plate (mill finished)
- G. Non-shrink self-levelling bedding compound (by others)
- H. Continuous extruded aluminium base frame (mill finished)
- I. Floor finish

Specification Style

Supply and install 120 metres C/S Allway Thinline Flush Seal™ series floor to floor expansion joint cover, model ref: GFT-100/20, complete with Black C/S TPR gasket.

Optional Clauses:

i) Reflex Fire Barrier, to suit 25mm joint width and providing minimum 2 hours integrity and insulation when installed in accordance with manufacturer's instructions.

ii) Vapour Barrier/Water Stop to suit 25mm joint width.

All manufactured and supplied by Construction Specialties (UK) Ltd, Conspec House, St Andrews Way, Bicester Road, Aylesbury, Bucks HP19 8AF Tel: 01296 611000

C/S Allway® Expansion Joint Covers

Twinline Flush Seal™ Floor Joint Covers (Interior Joints to 100mm)

Recess mounted floor joint covers incorporating dual durometer thermoplastic rubber gasket and an aluminium self-centring assembly retained in place by stainless steel spring clip.

- Flush floor finish
- Replaceable gasket
- Smooth, easy clean surface
- Multi directional movement

GFP

Floor covers with flush centre plate and dual C/S TPR gasket.

GFPW

The floor to wall version of GFP.

GFR

Floor covers with 3.2mm deep recessed centre plate to take a vinyl floor, bonded carpet or other insert.

GFRW

The floor to wall version of GFR.

GFRD

As GFR but with an extra deep (9.5mm) recess to take carpet or tiles.

GFRDW

The floor to wall version of GFRD.

Colours

Aluminium Sections - mill finished as standard, except for exposed wall frames and flush centre plates, which are supplied with clear anodised finish as standard. Other colours can be supplied subject to minimum quantity.

C/S TPR Gaskets – supplied in rolls up to 30 metres in length, in Black, White, Grey and Greige as standard (see general information page 34). Other colours can be made available, subject to quantity.

GFP-200. Twinline Flush Seal™ floor-to-floor joint cover.

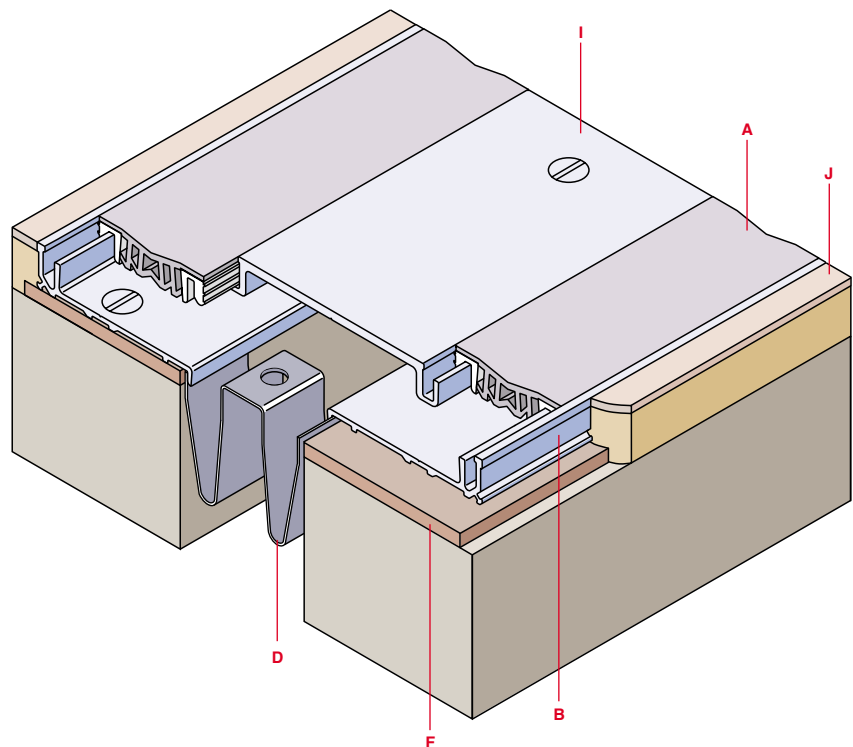

Product Data

Model	Number	Joint Width (mm)	Exposed Surface (mm)	Thermal Movement Capacity ±(mm)		
				Horizontal	Vertical	Lateral
GFP	200	50.0	165.0	±20.0	±12.0	±6.0
	300	75.0	254.0	±38.0	±12.0	±12.0
	400	100.0	280.0	±38.0	±12.0	±12.0
GFPW	200	50.0	108.0	±10.0	0	±3.0
	300	75.0	165.0	±19.0	0	±6.0
	400	100.0	191.0	±19.0	0	±6.0
GFR	200	50.0	165.0	±20.0	±12.0	±6.0
	300	75.0	254.0	±38.0	±12.0	±12.0
	400	100.0	280.0	±38.0	±12.0	±12.0
GFRW	200	50.0	108.0	±10.0	0	±3.0
	300	75.0	165.0	±19.0	0	±6.0
	400	100.0	191.0	±19.0	0	±6.0
GFRD	200	50.0	165.0	±20.0	0	±6.0
	300	75.0	254.0	±38.0	0	±12.0
	400	100.0	280.0	±38.0	0	±12.0
GFRDW	200	50.0	108.0	±10.0	0	±3.0
	300	75.0	165.0	±19.0	0	±6.0
	400	100.0	191.0	±19.0	0	±6.0

GFRD-200. Twinline Flush Seal™ floor-to-floor joint cover.

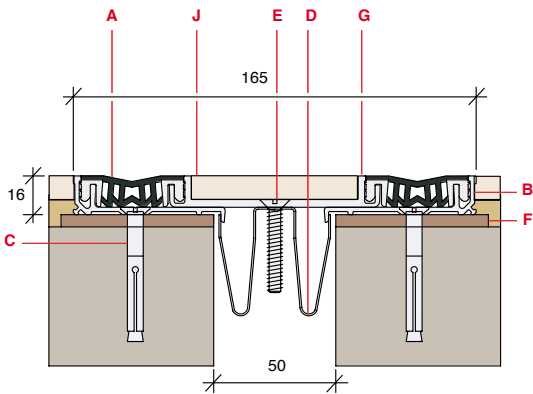

GFR-200. Twinline Flush Seal™ floor-to-floor joint cover.

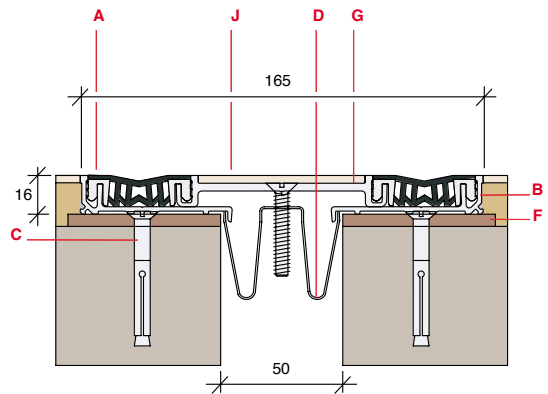

GFRDW-200. Twinline Flush Seal™ floor-to-wall joint cover.

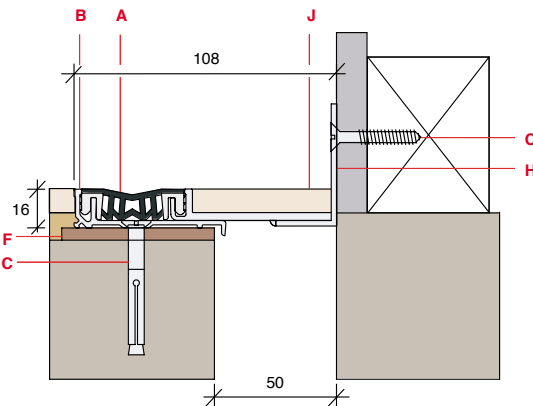

GFRW-200. Twinline Flush Seal™ floor-to-wall joint cover.

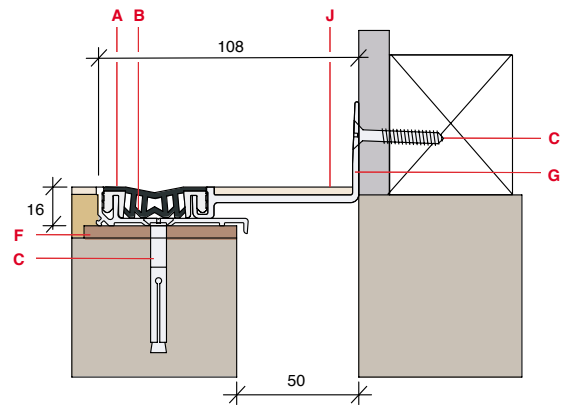

Key for diagrams

- A. C/S TPR gasket
- B. Continuous extruded aluminium side frame (mill finished)
- C. Fixing to suit substrate (by others), please refer to Product Data Sheet
- D. 50mm wide stainless steel spring clips at 450mm centres
- E. Machine screw
- F. Non-shrink self-levelling bedding compound (by others)
- G. Continuous extruded aluminium recessed centre plate, supplied mill finished (deep recess for models GFRD and GFRDW)
- H. Aluminium angle welded to centre plate (mill finished)
- I. Continuous extruded aluminium flush centre plate with clear anodised finish
- J. Floor finish

Specification Style

Supply and install 180 metres C/S Allway Twinline Flush Seal™ floor to floor expansion joint cover, model ref: GFR-200, complete with Black C/S TPR gasket.

Optional Clauses:

- i) Reflex Fire Barrier, to suit 50mm joint width and providing minimum 2 hours integrity and insulation when installed in accordance with manufacturer's instructions.
- ii) Vapour Barrier/Water Stop to suit 50mm joint width

All manufactured and supplied by Construction Specialties (UK) Ltd, Conspec House, St Andrews Way, Bicester Road, Aylesbury, Bucks HP19 8AF Tel: 01296 611000

C/S Allway® Expansion Joint Covers

Heavy Duty Floor Joint Covers (Interior/Exterior Joints to 100mm)

Specialised expansion joint covers for situations where the required loadings are far in excess of those normally encountered.

Twinline Flush Seal™ Heavy Duty Floor Joint Covers

GFP-HD

Heavy duty floor to floor covers for up to 100mm wide joints, which also allow some vertical shear movement.

GFPW-HD

Floor to wall version of GFP-HD

Heavy Duty Seal Floor Joint Covers

Recess mounted models

HO 50/40

Heavy duty floor to floor cover for 50mm wide joints

HO 50/40P

Floor to wall version of HO 50/40

HO 50/40PD

Similar to HO 50/40P but with an alternative, extended wall frame suitable for 65mm wide joints

Surface mounted models

RLO 50/31

Heavy duty floor to floor joint cover for 55mm wide joints

RLO 50/31P

Heavy duty floor to wall version of RLO-50/31

RLO 50/31PD

Similar to RLO 50/31P, but with an alternative extended wall frame, suitable for 70mm wide joints

Colours

Aluminium Sections – mill finished as standard, except for exposed wall frames and flush centre plates, which are supplied with clear anodised finish as standard. Other colours can be supplied subject to minimum quantity.

GFP-200HD. Twinline Flush Seal™ heavy duty floor-to-floor joint cover.

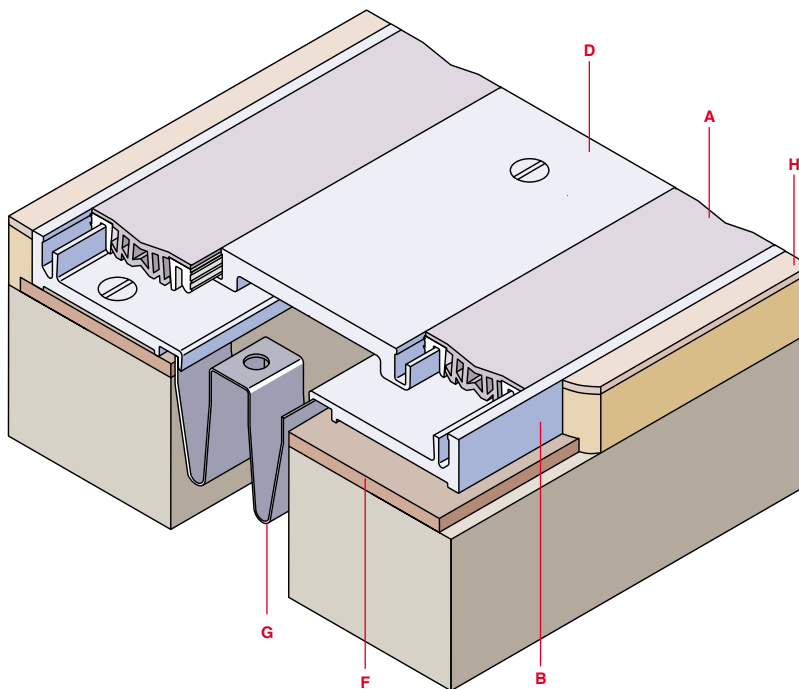

Product Data

Model	Number	Joint Width (mm)	Exposed Surface (mm)	Thermal Movement Capacity ±(mm)		
				Horizontal	Vertical	Lateral
GFP-HD	200	50.0	168.0	±20.0	±6.0	±6.0
	300	75.0	257.0	±38.0	±12.0	±12.0
	400	100.0	283.0	±38.0	±12.0	±12.0
GFPW-HD	200	50.0	110.0	±10.0	0	±3.0
	300	75.0	167.0	±19.0	0	±6.0
	400	100.0	192.0	±19.0	0	±6.0
HO	50/40	50.0	55.0	±10.0	0	0
	50/40P	50.0	55.0	±10.0	0	0
	50/40PD	65.0	70.0	±10.0	0	0
RLO	50/31	55.0	210.0	±10.0	0	0
	50/31P	55.0	130.0	±10.0	0	0
	50/31PD	70.0	145.0	±10.0	0	0

C/S TPR Gaskets (models GFP(W)-HD) – supplied in rolls up to 30 metres in length, in Black, White, Grey and Greige as standard (see general information page 34). Other colours can be made available, subject to quantity.

Flexible PVC Gaskets (models HO and RLO) – Black and Grey as standard.

HO-50/40. Heavy Duty Seal floor-to-floor joint cover.

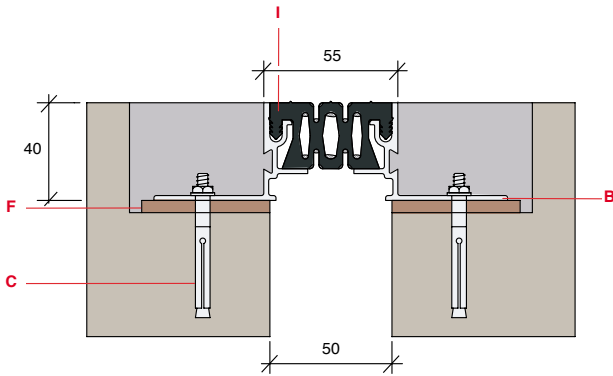

RLO-50/31. Heavy Duty Seal floor-to-floor joint cover.

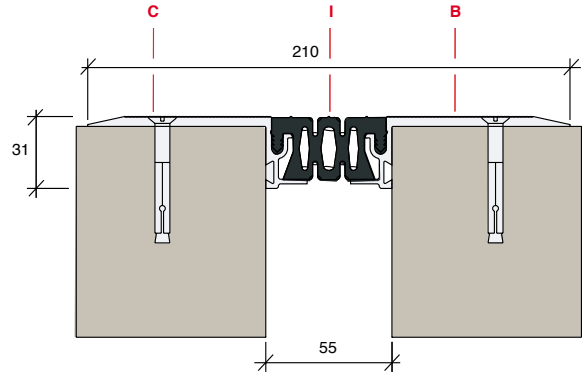

GFPW-200HD. Twinline Flush Seal™ heavy duty floor-to-wall joint cover.

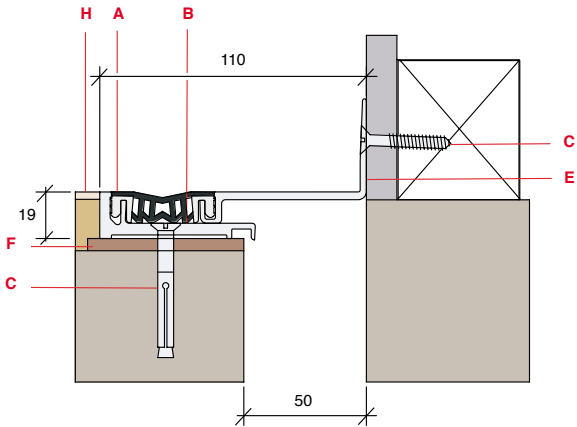

RLO-50/31PD. Heavy Duty Seal floor-to-wall joint cover.

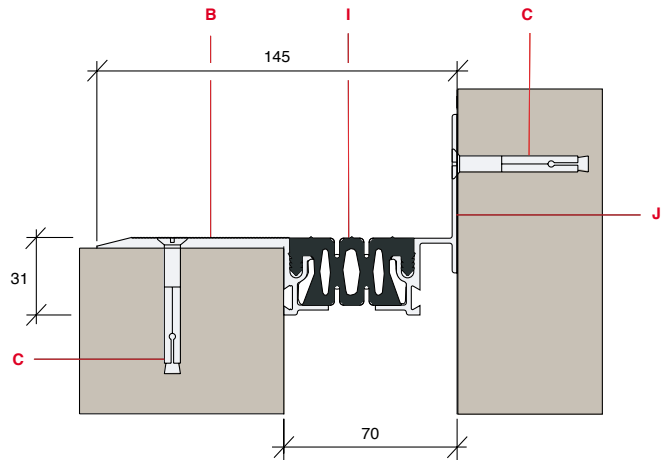

Key for diagrams

- A. C/S TPR gasket
- B. Continuous extruded aluminium side frame (mill finished)
- C. Fixing to suit substrate (by others), please refer to Product Data Sheet
- D. Continuous extruded aluminium centre plate with clear anodised finish
- E. Continuous extruded aluminium wall frame with clear anodised finish
- F. Non-shrink self levelling bedding compound (by others)
- G. 50mm wide stainless steel spring clips @ 450mm centres
- H. Floor finish
- I. Flexible PVC gasket (EPDM gasket optional)
- J. Continuous extruded aluminium wall frame (mill finished)

Specification Style

Supply and install 54 metres C/S Allway Twinline Flush Seal™ heavy duty floor to floor expansion joint cover, model ref: GFPW-200HD, complete with Grey C/S TPR Gasket.

Optional Clauses:

- i) Reflex Fire Barrier, to suit 50mm joint width and providing minimum 2 hours integrity and insulation when installed in accordance with manufacturer's instructions.
- ii) Vapour Barrier/Water Stop to suit 50mm joint width.

All manufactured and supplied by Construction Specialties (UK) Ltd, Conspec House, St Andrews Way, Bicester Road, Aylesbury, Bucks HP19 8AF
Tel: 01296 611000

C/S Allway® Expansion Joint Covers

All Metal™ Floor Joint Covers (Interior/Exterior Joints to 100mm)

All Metal™ recess mounted floor joint covers are designed to accommodate up to 100% horizontal movement of the joint width. Vertical movement is engineered to allow for non-aligning opposing slabs.

Standard Models

ALS

Floor joint covers utilising a free-floating centre plate held in position by serrated aluminium cover plates snap-locked into aluminium frames.

ALSW

The floor to wall version of ALS

ALSM

The new to existing version of ALS

ALX

Floor covers incorporating stainless steel centre plate and cover plates

ALXW

The floor to wall version of ALX

Heavy Duty Models

AL-HD

Heavy duty floor joint covers for up to 100mm wide joints

AL-HDC

AL-HD with secondary centre plate for areas where trolley traffic is prevalent.

ALW-HD

The floor to wall version of AL-HD

ALM-HD

The new to existing version of the AL-HD

Colours

Aluminium sections are mill finished as standard, except for centre plate and cover plates on ALS/W models which are supplied with clear anodised finish. Centre plate and cover plates for ALX/W models are in dull polished stainless steel as standard. Other colours can be supplied subject to minimum quantity.

ALS-200. All Metal™ floor-to-floor joint cover.

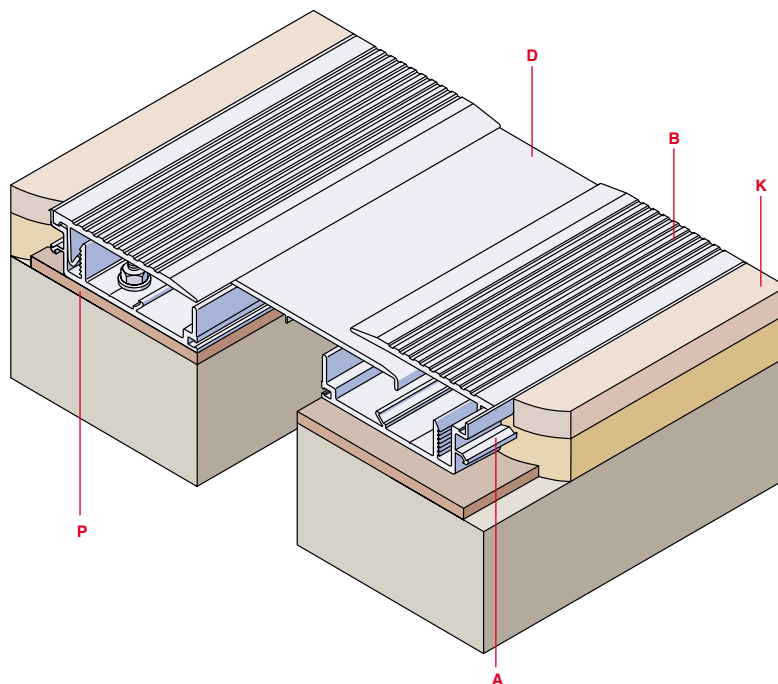

Product Data

Model	Number	Joint Width (mm)	Exposed Surface (mm)	Thermal Movement Capacity ±(mm)		
				Horizontal	Vertical	Lateral
ALS	100	25.0	127.0	±25.0	±3.0	∞
	200	50.0	197.0	±50.0	±3.0	∞
	300	75.0	273.0	±75.0	±3.0	∞
	400	100.0	299.0	±75.0	±3.0	∞
ALSW	100	25.0	76.0	±12.0	±3.0	∞
	200	50.0	124.0	±25.0	±3.0	∞
	300	75.0	175.0	±38.0	±3.0	∞
	400	100.0	200.0	±38.0	±3.0	∞
ALSM	100	25.0	127.0	±12.0	±3.0	∞
	200	50.0	174.0	±25.0	±3.0	∞
	300	75.0	224.0	±38.0	±3.0	∞
	400	100.0	249.0	±38.0	±3.0	∞
ALX	100	25.0	175.0	±20.0	0	∞
	200	50.0	200.0	±40.0	0	∞
ALXW	100	25.0	100.0	±10.0	0	∞
	200	50.0	125.0	±20.0	0	∞
AL-HD	100	25.0	127.0	±20.0	±3.0	∞
	200	50.0	228.0	±50.0	±3.0	∞
	400	100.0	318.0	±70.0	±3.0	∞
	400	100.0	318.0	±70.0	±3.0	∞
AL-HDC	200	50.0	228.0	±25.0	±3.0	∞
ALW-HD	100	25.0	76.0	±10.0	±3.0	∞
	200	50.0	139.0	±25.0	±3.0	∞
	400	100.0	210.0	±34.0	±3.0	∞
ALM-HD	200	50.0	190.0	±25.0	±3.0	∞
	400	100.0	260.0	±34.0	±3.0	∞

ALM-200HD. All Metal™ heavy duty new to existing floor-to-floor joint cover.

Note: FFL at this level should be 6mm higher than the existing floor level

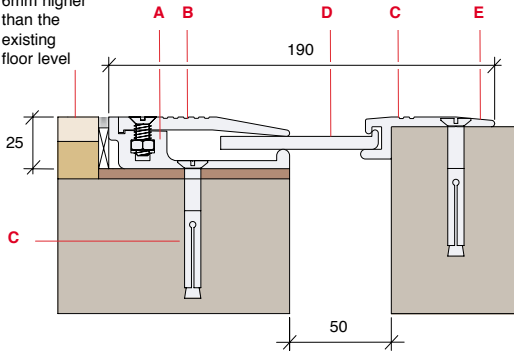

ALX-200. All Metal™ floor-to-floor joint cover.

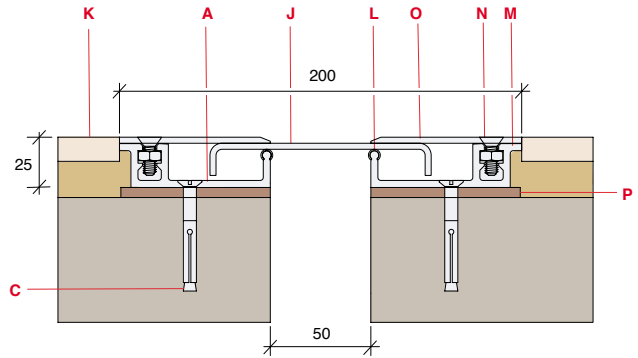

AL-200HD. All Metal™ heavy duty floor-to-floor joint cover.

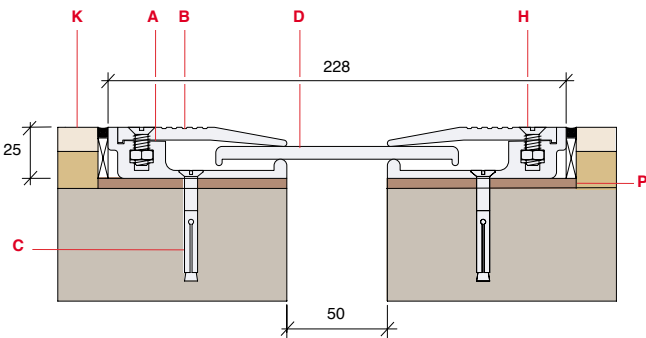

AL-200HDC. All Metal™ heavy duty floor-to-floor joint cover.

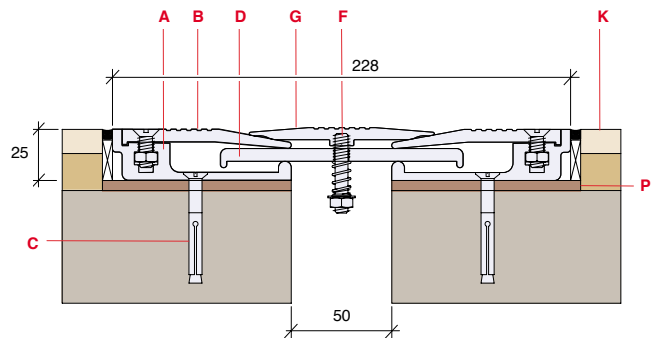

Key for diagrams

- A. Continuous extruded aluminium side frame (mill finished)
- B. Continuous extruded aluminium serrated cover plate (mill finished for heavy duty models, clear anodised for ALS (W/M) series models)
- C. Fixing to suit substrate (by others), please refer to Product Data Sheet
- D. Continuous extruded aluminium centre plate
- E. Continuous extruded aluminium serrated side frame (mill finished)
- F. M6 x38mm special securing bolt and spring assembly @ 600mm centres
- G. Continuous extruded aluminium secondary centre plate (mill finished)
- H. 6.4mm flat headed machine screw and nut @ 250mm centres
- J. Dull polished stainless steel centre plate
- K. Floor finish
- L. Vinyl isolation liner
- M. Isolation tape separation between stainless steel and aluminium surfaces.
- N. Machine screw fixings @ 300mm centres
- O. Dull polished stainless steel cover plate
- P. Non-shrink self-levelling bedding compound (by others)

Specification Style

Supply and install 90 metres C/S Allway All Metal™ series floor-to-floor expansion joint cover, model ref: ALS-300.

Optional Clauses:

- i) Reflex Fire Barrier, to suit 75mm joint width and providing minimum 2 hours integrity and insulation when installed in accordance with manufacturer's instructions.
- ii) Vapour Barrier/Water Stop to suit 75mm joint width.

All manufactured and supplied by Construction Specialties (UK) Ltd, Conspec House, St Andrews Way, Bicester Road, Aylesbury, Bucks HP19 8AF Tel: 01296 611000

C/S Allway® Expansion Joint Covers

Twinline Large Span Floor Joint Covers (Interior/Exterior Joints to 250mm)

Twinline Large Span floor joint covers are designed to span structural joints ranging from 100mm to 250mm.

- Totally flush finish
- Self-centering centre plate

SSR

Large span floor joint covers suitable for interior and exterior applications. Recessed centre plate capable of accepting up to 38mm deep marble, granite or limestone slabs, making the joint minimally visible.

SSRW

The floor to wall version of SSR

SGR

Large span joint with twin C/S TPR gaskets and a recessed cover plate to allow a flush floor finish

SGRW

The floor to wall version of SGR

SGP

As the SGR but with a plain cover plate. Optional bronze anodised or stainless steel cover plate.

SGPW

The floor to wall version of SGP

Colours

Aluminium sections – mill finished as standard, except for SGP models centre plate, which is supplied with clear anodised finish as standard. Other colours can be supplied subject to minimum quantity.

C/S TPR Gaskets – supplied in rolls up to 30 metres in length, in Black, White, Grey and Greige as standard (see general information page 34). Other colours can be made available, subject to quantity.

SSR-400. Twinline Large Span floor-to-floor joint cover.

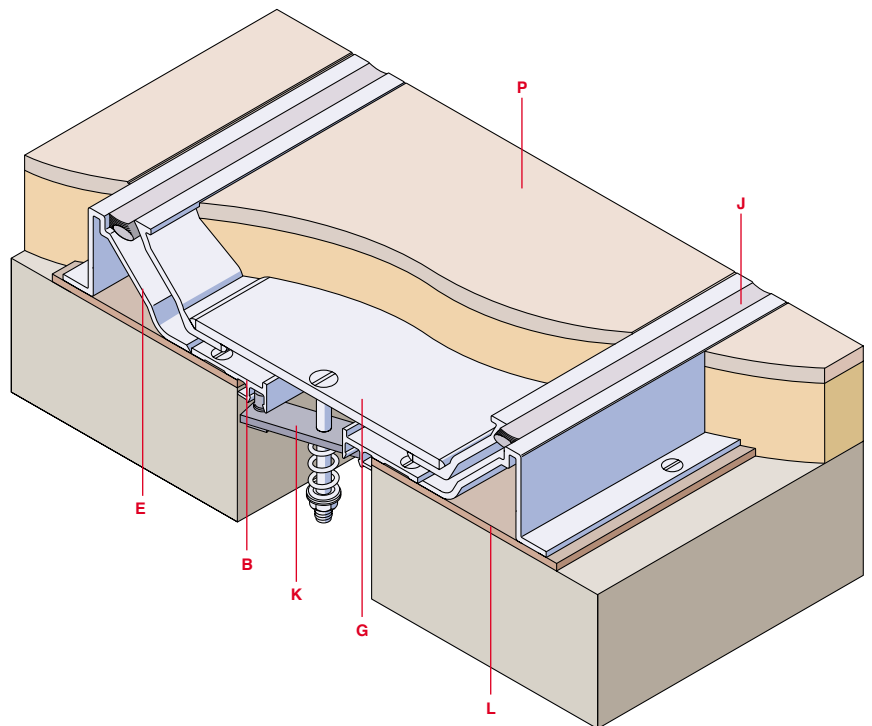

Product Data

Model	Number	Joint Width (mm)	Exposed Surface (mm)	Thermal Movement Capacity ±(mm)			Complementary Wall/ Ceiling Joint Covers
				Horizontal	Vertical	Lateral	
SSR*	400	100.0	328.0	±20.0	0	±6.0	N/A
	500	125.0	352.0	±20.0	0	±6.0	N/A
	600	150.0	378.0	±20.0	0	±6.0	N/A
	700	175.0	403.0	±20.0	0	±6.0	N/A
	800	200.0	479.0	±20.0	0	±6.0	N/A
	900	225.0	505.0	±20.0	0	±6.0	N/A
SSRW*	400	100.0	214.0	±10.0	0	±3.0	N/A
	500	125.0	240.0	±10.0	0	±3.0	N/A
	600	150.0	265.0	±10.0	0	±3.0	N/A
	700	175.0	291.0	±10.0	0	±3.0	N/A
	800	200.0	341.0	±10.0	0	±3.0	N/A
	900	225.0	367.0	±10.0	0	±3.0	N/A
SGR*/SGP*	400	100.0	280.0	±25.0	±3.0	±12.0	N/A
	500	125.0	305.0	±25.0	±3.0	±12.0	SGW-500
	600	150.0	330.0	±25.0	±3.0	±12.0	SGW-600
	700	175.0	381.0	±25.0	±3.0	±12.0	SGW-700
	800	200.0	406.0	±25.0	±3.0	±12.0	SGW-800
	900	225.0	457.0	±25.0	±3.0	±12.0	SGW-900
SGRW*/SGPW*	400	100.0	191.0	±12.0	0	±6.0	N/A
	500	125.0	216.0	±12.0	0	±6.0	SGWC-500
	600	150.0	241.0	±12.0	0	±6.0	SGWC-600
	700	175.0	279.0	±12.0	0	±6.0	SGWC-700
	800	200.0	311.0	±12.0	0	±6.0	SGWC-800
	900	225.0	342.0	±12.0	0	±6.0	SGWC-900
	1000	250.0	368.0	±12.0	0	±6.0	SGWC-1000

* These joint covers can be used in seismic areas. Larger sizes available. For details contact our Technical Department on 01296 611000

SGP-400. Twinline Large Span floor-to-floor joint cover.

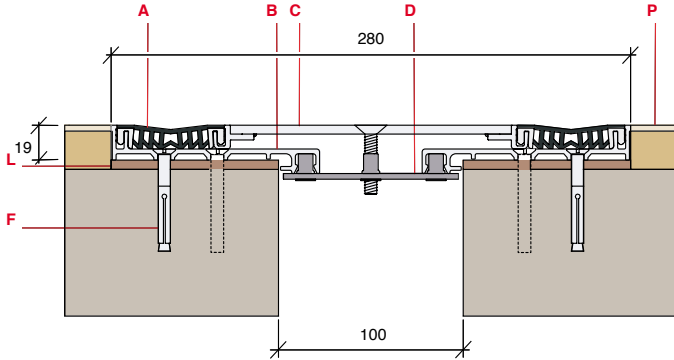

SGR-400. Twinline Large Span floor-to-floor joint cover.

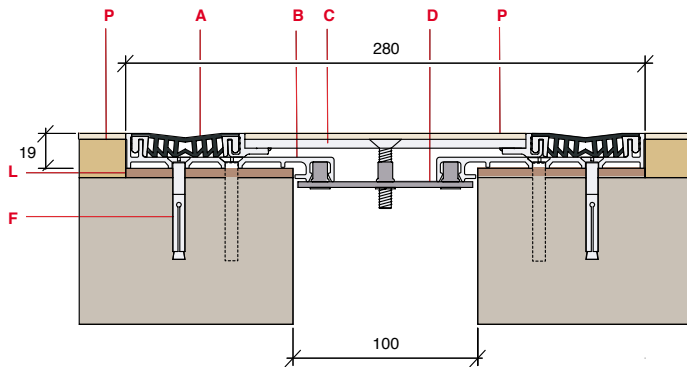

SSRW-400. Twinline Large Span floor-to-wall joint cover.

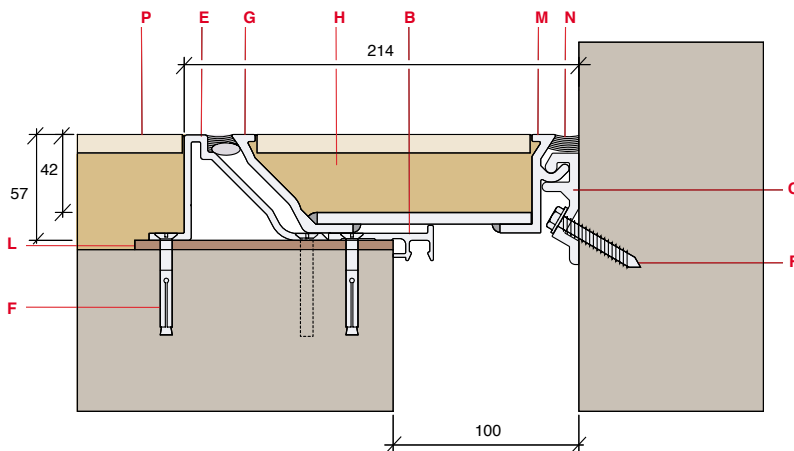

Key for diagrams

- A. C/S TPR gasket
- B. Continuous extruded aluminium turnbar frame
- C. Aluminium centre plate (flush for SGP/W models and recessed for SGR/W models) welded to aluminium adaptors
- D. Steel turnbar assembly @ 450mm centres
- E. Continuous extruded aluminium frame
- F. Fixing to suit substrate (by others), please refer to Product Data Sheet
- G. Continuous extruded aluminium pan nosing (welded to aluminium centre plate)
- H. Self levelling grout (by others) to be installed on site
- J. Caulk and backer rod (by others)
- K. Steel channel turnbar assembly @ 450mm centres
- L. Non-shrink self-levelling bedding compound (by others)
- M. Continuous extruded aluminium hinge nosing welded to aluminium centre plate
- N. Caulk (by others)
- O. Continuous extruded aluminium hinge frame
- P. Floor finish

Specification Style

Supply and install 42 meters C/S Allway Twinline Large Span floor to wall expansion joint cover, model ref: SGRW-800.

Optional Clauses:

- i) Multiflex Fire Barrier, to suit 200mm joint width and providing minimum 2 hours integrity and insulation when installed in accordance with manufacturer's instructions.
- ii) Vapour Barrier/Water Stop to suit 200mm joint width.

All manufactured and supplied by Construction Specialties (UK) Ltd, Conspec House, St Andrews Way, Bicester Road, Aylesbury, Bucks HP19 8AF. Tel: 01296 611000

C/S Allway® Expansion Joint Covers

All Metal™ Large Span Floor Joint Covers (Interior/Exterior Joints to 250mm)

All Metal™ floor joint covers designed to span structural joints ranging from 100mm to 250mm. All floor-to-floor joints are working on a rotating centre-pivot design allowing up to ±50% horizontal movement of the working joint width.

- Self-centering centre plate with stainless steel turnbar assembly
- Bronze and stainless steel covers available

Standard Models

SJP

Aluminium floor joint covers with a cover plate sitting over a standard floor finish

SJPW

Floor to wall version of SJP

SJPF

Aluminium floor joint covers with a flush fitting cover plate

SJPFW

Floor to wall version of SJPF

Heavy Duty Models

SJ-HD

Heavy duty version of SJPF series

SJW-HD

Floor to wall version of SJ-HD

Colours

Aluminium sections – mill finished as standard, except for exposed surfaces on standard models, which are supplied with clear anodised finish. Other colours can be supplied subject to minimum quantity.

SJ-400HD. All Metal™ Large Span heavy duty floor-to-floor cover.

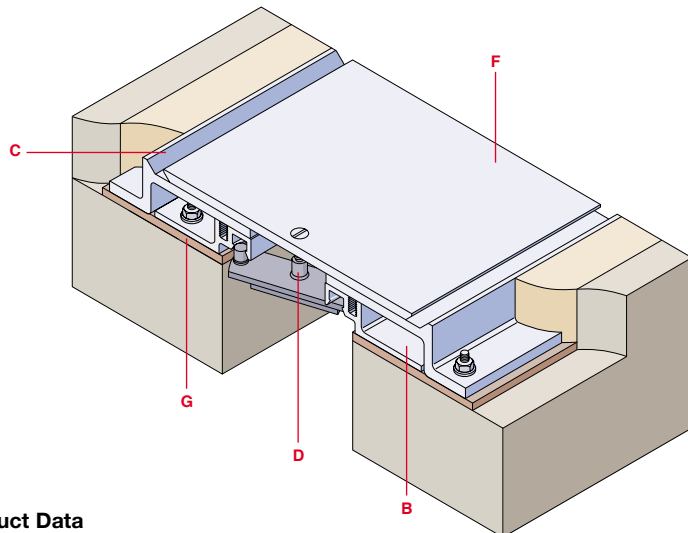

Product Data

Model	Number	Joint Width (mm)	Exposed Surface (mm)	Thermal Movement Capacity ±(mm)			
				Horizontal	Vertical	Lateral	
SJP*	200	50.0	89.0	±25.0	0	±50.0	
	300	75.0	165.0	±37.0	0	±50.0	
	400	100.0	191.0	±50.0	0	±50.0	
	500	125.0	267.0	±62.0	0	±50.0	
	600	150.0	302.0	±75.0	0	±50.0	
	700	175.0	343.0	±87.0	0	±50.0	
SJPW*	800	200.0	381.0	±100.0	0	±50.0	
	900	225.0	419.0	±112.0	0	±50.0	
	1000	250.0	454.0	±125.0	0	±50.0	
	200	50.0	82.0	±12.0	0	±25.0	
SJPF	300	75.0	121.0	±19.0	0	±25.0	
	400	100.0	146.0	±25.0	0	±25.0	
	500	125.0	191.0	±32.0	0	±25.0	
	600	150.0	229.0	±37.0	0	±25.0	
	700	175.0	260.0	±44.0	0	±25.0	
	800	200.0	292.0	±50.0	0	±25.0	
	900	225.0	324.0	±57.0	0	±25.0	
	1000	250.0	356.0	±63.0	0	±25.0	
	SJPFW	200	50.0	140.0	±12.0	0	±12.0
		300	75.0	178.0	±12.0	0	±12.0
400		100.0	216.0	±12.0	0	±12.0	
500		125.0	254.0	±12.0	0	±12.0	
600		150.0	292.0	±12.0	0	±12.0	
200		50.0	92.0	±6.0	0	±6.0	
SJ-HD	300	75.0	127.0	±6.0	0	±6.0	
	400	100.0	159.0	±6.0	0	±6.0	
	500	125.0	191.0	±6.0	0	±6.0	
	600	150.0	222.0	±6.0	0	±6.0	
	400	100.0	222.0	±25.0	0	±12.0	
SJW-HD	500	125.0	248.0	±25.0	0	±12.0	
	600	150.0	298.0	±25.0	0	±12.0	
	700	175.0	349.0	±25.0	0	±12.0	
	800	200.0	375.0	±25.0	0	±12.0	
SJW-HD	400	100.0	162.0	±12.0	0	±6.0	
	500	125.0	187.0	±12.0	0	±6.0	
	600	150.0	226.0	±12.0	0	±6.0	
	700	175.0	264.0	±12.0	0	±6.0	
	800	200.0	314.0	±12.0	0	±6.0	

These joint covers can be used in seismic areas. * Larger sizes available. For details contact our Technical Department on 01296 611000

SJW-400HD. All Metal™ Large Span heavy duty floor-to-wall joint cover.

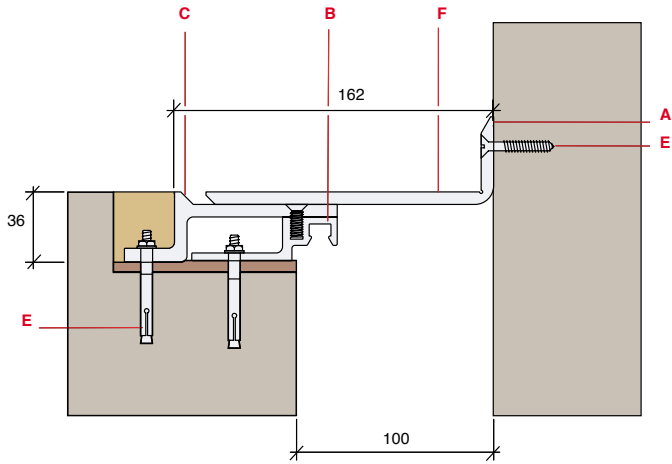

Key for diagrams

- A. Aluminium centre plate with clear anodised finish
- B. Continuous extruded aluminium turnbar frame
- C. Continuous extruded aluminium heavy duty frame (mill finished)
- D. Steel turnbar assembly @ 450mm centres
- E. Fixing to suit substrate (by others), please refer to Product Data Sheet
- F. Aluminium centre plate (angled for SJW-HD models) supplied mill finished
- G. Non-shrink self levelling bedding compound (by others)
- H. Floor finish

Specification Style

Supply and install 40 meters C/S Allway All Metal™ Large Span floor to floor expansion joint cover, model ref: SJP-800.

Optional Clauses:

- i) Multiflex Fire Barrier, to suit 200mm joint width and providing minimum 2 hours integrity and insulation when installed in accordance with manufacturer's instructions.
- ii) Vapour Barrier/Water Stop to suit 200mm joint width.

All manufactured and supplied by Construction Specialties (UK) Ltd, Conspic House, St Andrews Way, Bicester Road, Aylesbury, Bucks HP19 8AF Tel: 01296 611000

SJP-400. All Metal™ Large Span floor-to-floor joint cover.

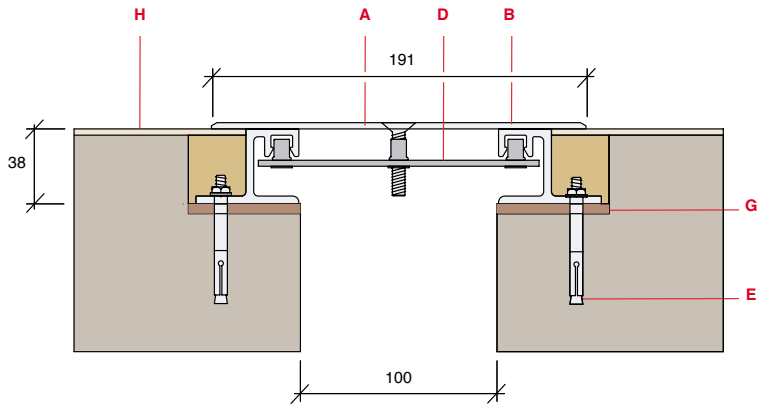

SJPF-400. All Metal™ Large Span floor-to-floor joint cover.

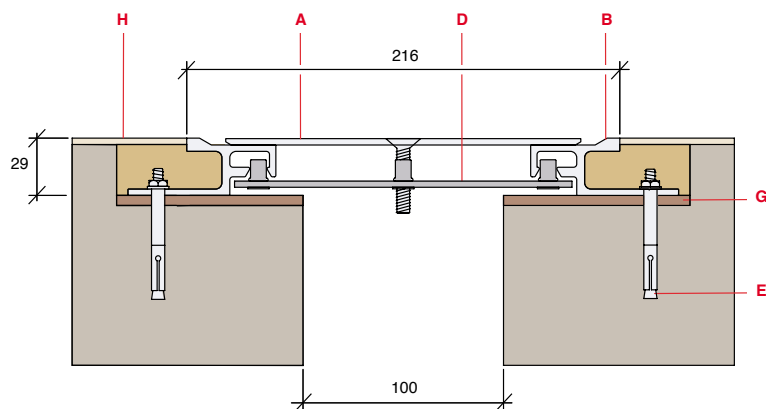

C/S Allway® Expansion Joint Covers

Parking Joints and Elastomeric Seals

C/S Group offers a complete line of expansion joint covers that meet the demanding movement conditions found in parking structures.

CSS

Series of compressions seals complete with extruded aluminium support frames

ZB

One-piece EPDM compression seal with integral nosing that zips instantaneously into concrete blockouts once the epoxy bed is applied. The system is fast, neat and installs over green concrete.

KB

Series of joint covers featuring the patented turnbar housing which reduces lateral load damage. Special design of the centre plate offers maximum strength yet minimal interference with pedestrians.

KBW

Floor to wall version of KB

PTC

The design of this joint cover allows for significant deflection of the adjacent floor slabs and a variable rotation damper system prevents the cover plate from "flapping" noisily under traffic loads. The centre plate is fully interchangeable.

PTCW

The floor to wall version of PTC

Colours

Compression seals typically black. Other colours available subject to minimum quantity. Aluminium sections are mill finished as standard. PTC model – centre plate mill finished aluminium as standard, steel option available.

PTC-600. Large Span Parking floor-to-floor joint cover.

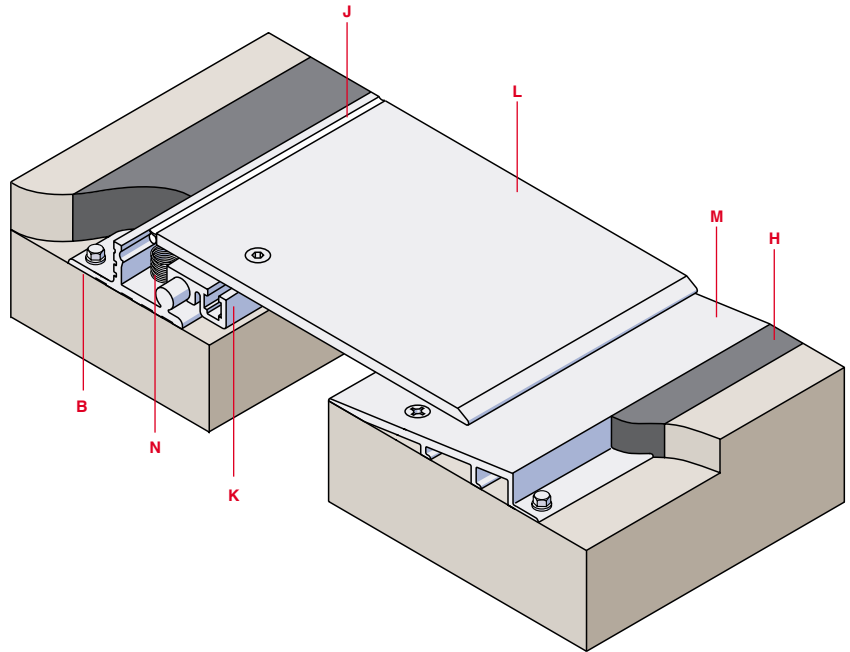

Product Data

Model	Number	Joint Width (mm)	Exposed Surface (mm)	Thermal Movement Capacity ±(mm)		
				Horizontal	Vertical	Lateral
CSS	100	25.0	35.0	±10.0	±3.0	0
	150	37.5	48.0	±12.0	±3.0	0
	200	50.0	61.0	±14.0	±3.0	0
ZB	200	50.0	229.0	±25.0	0	0
	300	75.0	254.0	±38.0	0	0
	400	100.0	278.0	±50.0	0	0
KB	400	100.0	432.0	±50.0	±6.0	±50.0
	500	125.0	533.0	±63.0	±9.0	±63.0
	600	150.0	559.0	±75.0	±12.0	±75.0
	700	175.0	635.0	±87.0	±15.0	±87.0
	800	200.0	660.0	±100.0	±18.0	±100.0
KBW	400	100.0	267.0	±25.0	±3.0	±25.0
	500	125.0	330.0	±32.0	±4.0	±32.0
	600	150.0	356.0	±38.0	±6.0	±38.0
	700	175.0	406.0	±44.0	±7.0	±44.0
PTC*	600	200.0	432.0	±50.0	±9.0	±50.0
	600	150.0	620.0	±50.0	±19.0	±50.0
	700	175.0	648.0	±50.0	±19.0	±50.0
	800	200.0	673.0	±50.0	±19.0	±50.0
PTCW*	900	225.0	699.0	±50.0	±19.0	±50.0
	1000	250.0	749.0	±50.0	±19.0	±50.0
	600	150.0	426.0	±25.0	±19.0	±25.0
	700	175.0	451.0	±25.0	±19.0	±25.0
	800	200.0	476.0	±25.0	±19.0	±25.0
PTCW*	900	225.0	502.0	±25.0	±19.0	±25.0
	1000	250.0	553.0	±25.0	±19.0	±25.0

KB(W) and PTC(W) models can be used in seismic areas.

* Larger sizes available. For details contact our Technical Department on 01296 611000

KB-600. Large Span Parking floor-to-floor joint cover.

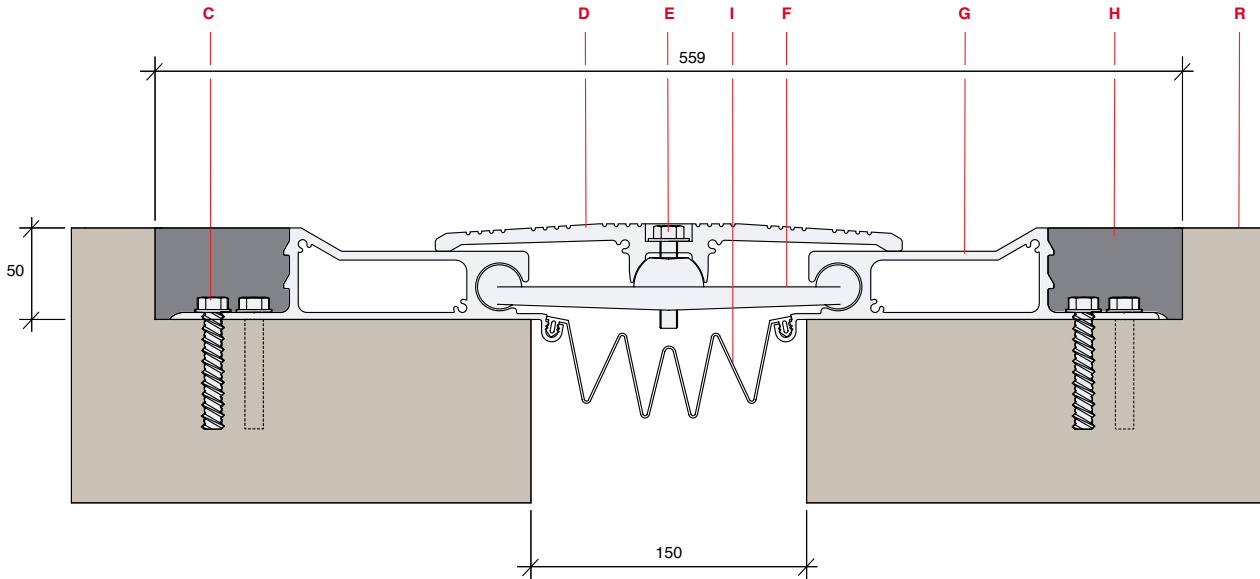

ZB-400. Exterior floor-to-floor joint cover.

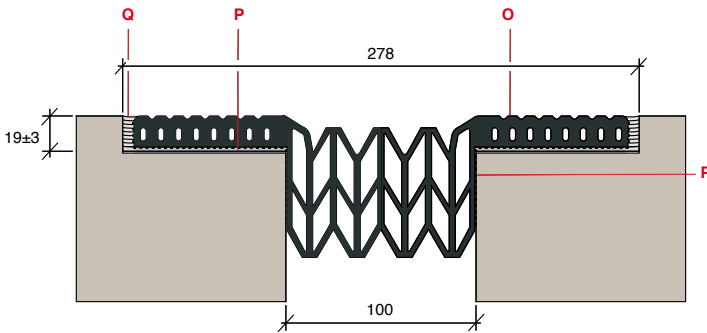

Key for diagrams

- A. Extruded EPDM compression seal
- B. Continuous extruded aluminium side frame (mill finished)
- C. Fixing to suit substrate (by others), please refer to Product Data Sheet
- D. Continuous extruded aluminium centre plate (mill finished)
- E. Cap Screw and washer
- F. Cast aluminium turnbar
- G. Continuous extruded aluminium frame
- H. C/S elastomeric concrete
- I. Water stop
- J. Backer rod and sealant
- K. Continuous extruded aluminium rotational frame
- L. Aluminium or steel centre plate
- M. Continuous extruded aluminium ramped frame
- N. Compression spring
- O. Zip Block seal
- P. Epoxy
- Q. Caulk
- R. Floor finish
- S. Non shrink self levelling bedding compound (by others)

CSS-200. Exterior floor-to-floor joint cover.

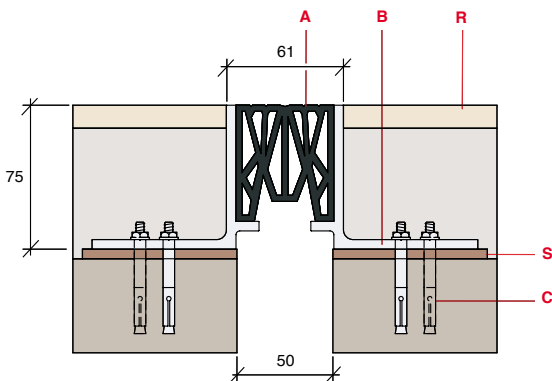

Specification Style

Supply and install 25 meters C/S Allway Large Span Parking floor to floor joint cover, model ref: PTC-600.

Optional clauses:

i) Multiflex Fire Barrier, to suit 150mm joint width and providing minimum 2 hours integrity and insulation when installed in accordance with manufacturer's instructions.

ii) Vapour Barrier/Water Stop to suit 150mm joint width.

All manufactured and supplied by Construction Specialties (UK) Ltd, Consep House, St Andrews Way, Bicester Road, Aylesbury, Bucks HP19 8AF Tel: 01296 611000

C/S Allway® Expansion Joint Covers

Thinline Flush Seal™ Wall and Ceiling Joint Covers (Interior Joints to 100mm)

Thinline Flush Seal™ wall/ceiling joint covers feature an easily replaceable, co-extruded C/S TPR Gasket, which has been designed to remain flush and in place during the entire movement cycle. Both surface and recess mounted models are available.

- Flush wall and ceiling finish
- Replaceable gasket
- Smooth, easy clean surface
- Multi directional movement

FGFS

Surface mounted expansion joint covers suitable for most types of wall construction

FGFSC

The corner, or wall to ceiling versions of FGFS

FWF

Standard flush finish recess mounted expansion joint covers for dry lined walls

FWFC

The corner, or wall to ceiling versions of FWF

FWFP

Similar to FWF, but designed for use with plaster finished walls

FWFPC

The corner, or wall to ceiling versions of FWFP

Colours

Aluminium sections are clear anodised as standard for surface mounted models and mill finished for recess mounted models.

Other colours can be supplied subject to minimum quantity.

C/S TPR Gaskets – supplied in rolls up to 30 metres in length, in Black, White, Grey and Greige as standard (see general information page 34). Other colours can be made available, subject to quantity.

FWF-100. Thinline Flush Seal™ wall-to-wall joint cover.

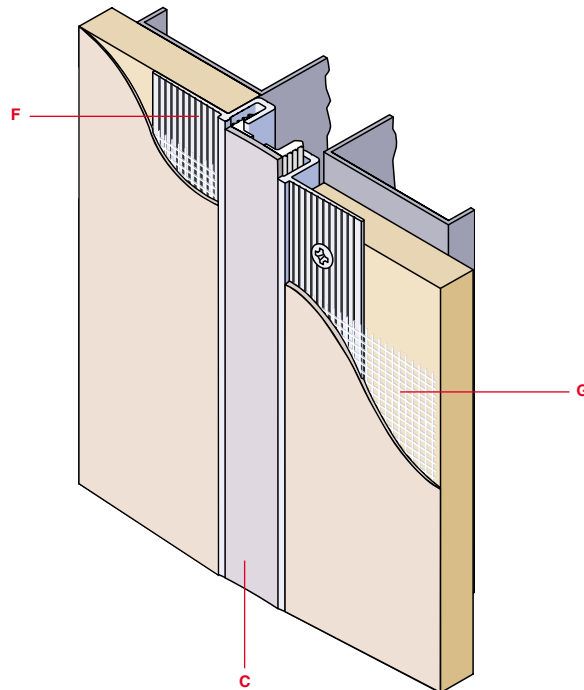

Product Data

Model	Number	Joint Width (mm)	Exposed Surface (mm)	Thermal Movement Capacity ±(mm)			Complementary Floor Joint Covers
				Horizontal	Vertical	Lateral	
FGFS	80	20.0	105.0	3.0	0	0	GFS-80
	100	25.0	110.0	5.0	±3.0	0	GFS-100 or GFST-100
	200	50.0	130.0	10.0	±3.0	±3.0	GFS-200 or GFST-200
FGFSC	80	20.0	63.0	3.0	0	0	GFSW-80
	100	25.0	67.0	5.0	±3.0	0	GFSW-100 or GFSTW-100
	200	50.0	90.0	10.0	±3.0	±3.0	GFSW-200 or GFSTW-200
FWF	100	25.0	27.0	5.0	±3.0	0	GFPS-100
	200	50.0	48.0	10.0	±3.0	±3.0	GFPS-200
FWFC	100	25.0	24.0	5.0	±3.0	0	GFPSW-100 or GFTW-100
	200	50.0	49.0	10.0	±3.0	±3.0	GFPSW-200 or GFTW-200
FWFP	100	25.0	26.0	5.0	±3.0	0	GFT-100
	200	50.0	48.0	10.0	±3.0	±3.0	GFT-200
FWFPC	100	25.0	26.0	5.0	±3.0	0	GFTW-100
	200	50.0	48.0	10.0	±3.0	±3.0	GFTW-200

FGFS-80. Thinline Flush Seal™ wall-to-wall joint cover.

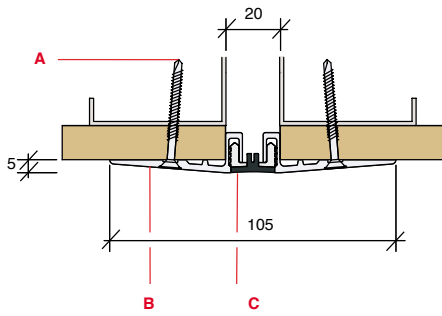

FGFSC-80. Thinline Flush Seal™ corner wall joint cover.

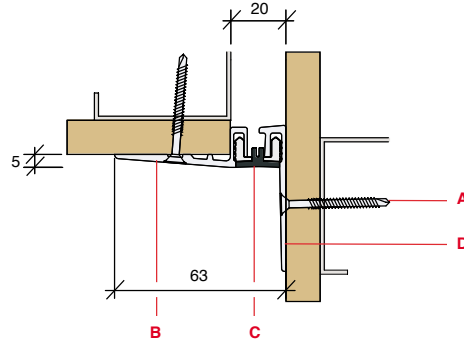

FWFC-100. Thinline Flush Seal™ corner wall joint cover.

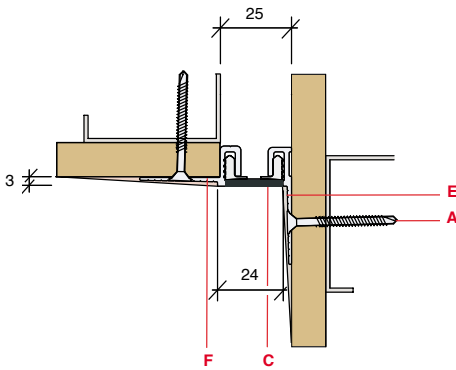

FWFPC-200. Thinline Flush Seal™ corner wall joint cover.

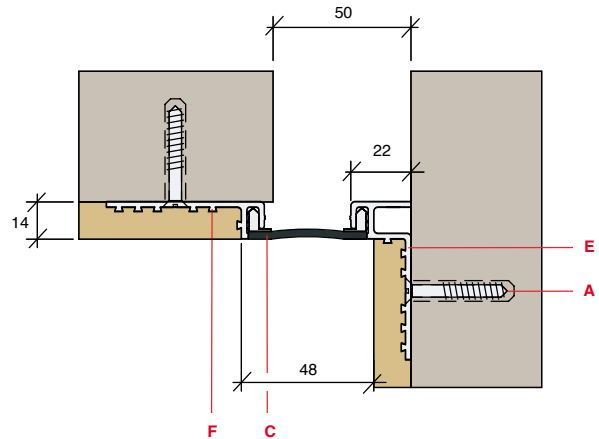

Key for diagrams

- A. Fixing to suit substrate (by others), please refer to Product Data Sheet
- B. Continuous extruded aluminium wall frame with clear anodised finish
- C. C/S TPR gasket
- D. Continuous extruded aluminium corner wall frame with clear anodised finish
- E. Continuous extruded aluminium corner wall frame (mill finished)
- F. Continuous extruded aluminium wall frame (mill finished)
- G. 50mm wide self-adhesive fibreglass scrim tape (by others).

Specification Style

Supply and install 85 metres C/S Allway Thinline Flush Seal™ wall to wall expansion joint cover, model ref: FGFS-200, complete with Grey C/S TPR gasket.

Optional Clauses:

- i) Reflex Fire Barrier, to suit 50mm joint width and providing minimum 2 hours integrity and insulation when installed in accordance with manufacturer's instructions.

All manufactured and supplied by Construction Specialties (UK) Ltd,
 Conspec House, St Andrews Way, Bicester Road, Aylesbury, Bucks HP19 8AF.
 Tel: 01296 611000

C/S Allway® Expansion Joint Covers

Thinline Flush Seal™ Wall and Ceiling Joint Covers (Interior Joints to 100mm)

Recess mounted wall/ceiling expansion joint covers incorporating a 'concertina' type continuous extruded flexible primary seal.

- Flush wall and/or ceiling finish
- Replaceable primary seal
- Multi directional movement

FWS

Wall or ceiling covers incorporating a 'concertina' type primary seal.

FWSC

The corner versions of FWS

FCS

'Concertina' type suspended ceiling joint covers.

FCSC

The corner versions of FCS

HC

'Concertina' type suspended ceiling joint covers incorporating continuous co-extruded white PVC.

Colours

Aluminium sections are mill finished as standard. Other colours can be supplied subject to minimum quantity.

'Concertina' type primary seals available in

Black, Grey and White as standard (see general information page 34). Other colours can be made available, subject to quantity.

HC model incorporates white co-extruded

PVC

FWS-200. Thinline Flush Seal™ wall-to-wall joint cover.

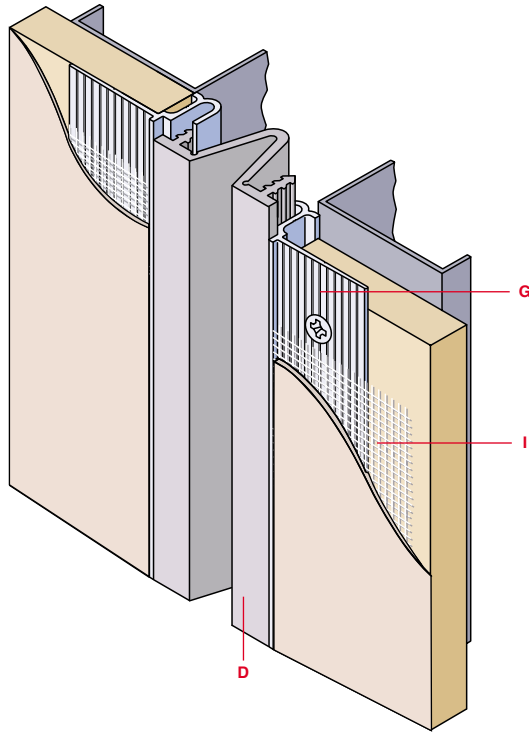

Product Data

Model	Number	Joint Width (mm)	Exposed Surface (mm)	Thermal Movement Capacity ±(mm)		
				Horizontal	Vertical	Lateral
FWS	200	50.0	50.0	±25.0	±6.0	±6.0
	300	75.0	75.0	±50.0	±6.0	±6.0
	400	100.0	100.0	±75.0	±6.0	±6.0
FWSC	200	50.0	50.0	±25.0	±6.0	±6.0
	300	75.0	75.0	±50.0	±6.0	±6.0
	400	100.0	100.0	±75.0	±6.0	±6.0
FCS	200	50.0	50.0	±25.0	±6.0	±6.0
	300	75.0	75.0	±50.0	±6.0	±6.0
	400	100.0	100.0	±75.0	±6.0	±6.0
FCSC	200	50.0	50.0	±25.0	±6.0	±6.0
	300	75.0	75.0	±50.0	±6.0	±6.0
	400	100.0	100.0	±75.0	±6.0	±6.0
HC	100	25.0	25.0	±25.0	±3.0	0
	200	50.0	50.0	±25.0	±3.0	0
	300	75.0	75.0	±50.0	±3.0	0
	400	100.0	100.0	±50.0	±3.0	0

FCS-300. Thinline Flush Seal™ ceiling joint cover.

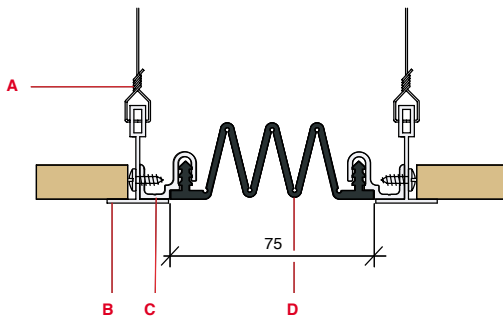

FCSC-300. Thinline Flush Seal™ ceiling-to-wall joint cover.

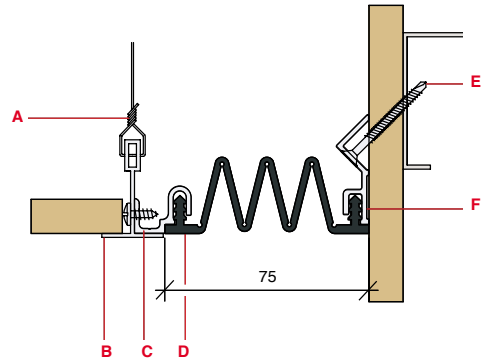

FWSC-200. Thinline Flush Seal™ corner wall joint cover.

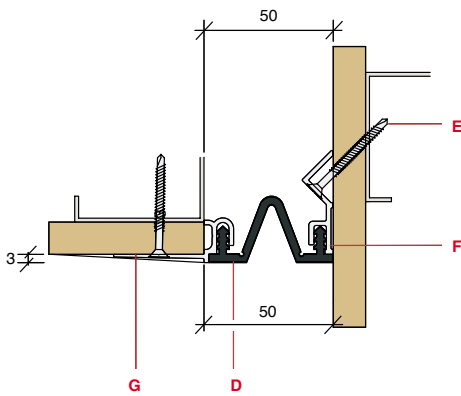

HC-100. Thinline Flush Seal™ ceiling joint cover.

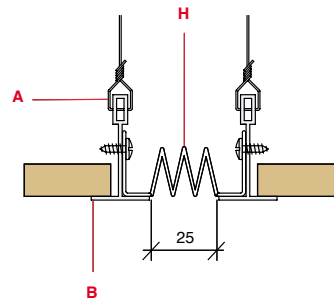

Key for diagrams

- A. Suspended ceiling hanger (by others)
- B. Suspended ceiling (by others)
- C. Continuous extruded aluminium ceiling frame (mill finished)
- D. Flexible primary seal
- E. Fixing to suit substrate (by others), please refer to Product Data Sheet
- F. Continuous extruded aluminium corner wall frame (mill finished)
- G. Continuous extruded aluminium wall frame (mill finished)
- H. Continuous co-extruded white PVC
- I. 50mm wide self-adhesive fibreglass scrim tape (by others).

Specification Style

Supply and install 105 metres C/S Allway Thinline Flush Seal™ ceiling to ceiling expansion joint cover, model ref: FCS-200, complete with White C/S TPR gasket.

Optional Clauses:

- i) Reflex Fire Barrier, to suit 50mm joint width and providing minimum 2 hours integrity and insulation when installed in accordance with manufacturer's instructions.

All manufactured and supplied by Construction Specialties (UK) Ltd, Conspec House, St Andrews Way, Bicester Road, Aylesbury, Bucks HP19 8AF
Tel: 01296 611000

C/S Allway® Expansion Joint Covers

All Metal™ Wall and Ceiling Joint Covers (Interior Joints to 50mm)

Series of aluminium surface mounted wall joint covers which can be used as ceiling joint covers where the construction permits.

SM

Wall joint covers for 25mm and 50mm joints.

SMC

The corner version of SM.

Colours

Standard finish is clear anodise. Other colours, or polyester powder coating, available subject to minimum quantity.

SM-200. All Metal™ wall-to-wall joint cover.

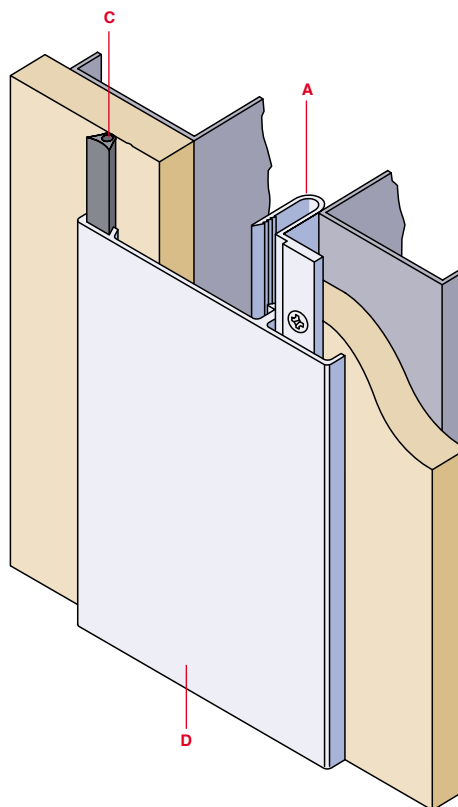

SMC-200. All Metal™ corner wall joint cover.

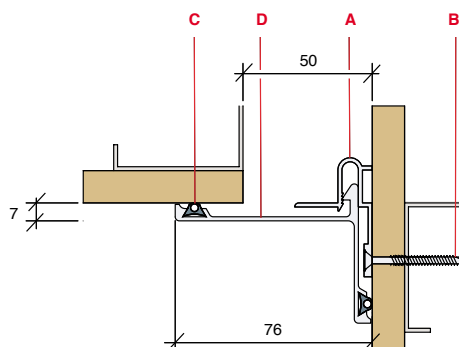

Key for diagrams

- A. Continuous extruded aluminium anchor clip
- B. Fixing to suit substrate (by others), please refer to Product Data Sheet
- C. Gasket
- D. Continuous extruded aluminium cover plate

Specification style

Supply and install 38 metres C/S Allway All Metal™ wall to wall expansion joint cover, model ref: SM-200.

Optional Clauses:

- i) Reflex Fire Barrier, to suit 50mm joint width and providing minimum 2 hours integrity and insulation when installed in accordance with manufacturer's instructions.

All manufactured and supplied by Construction Specialties (UK) Ltd, Conspec House, St Andrews Way, Bicester Road, Aylesbury, Bucks HP19 8AF.
Tel: 01296 611000

Product Data

Model	Number	Joint Width (mm)	Exposed Surface (mm)	Thermal Movement Capacity ±(mm)		
				Horizontal	Vertical	Lateral
SM	100	25.0	63.0	±16.0	0	0
	200	50.0	102.0	±25.0	0	0
SMC	100	25.0	45.0	±16.0	0	0
	200	50.0	76.0	±25.0	0	0

C/S Allway® Expansion Joint Covers

Large Span Wall Joint Covers (Interior and Exterior Joints to 250mm)

SGW

Series of interior wall joint covers featuring C/S TPR Gaskets, designed for large wall joints where a flush finish is required. The aluminium faced centre plate can be painted or covered for maximum concealment.

SGWC

The corner version of SGW

SC

These 'concertina' type profiles incorporate primary and secondary seals and have no exposed fasteners. Heat welded weather tight transitions and primary seals containing UV inhibitors, to prevent embrittlement and fading, making them especially suitable for exterior applications.

Colours

Visible aluminium sections - standard finish is clear anodise. Other colours can be supplied subject to minimum quantity.
C/S TPR Gaskets – supplied in rolls up to 30 metres in length, in Black, White, Grey and Greige as standard (see general information page 34). Other colours can be made available, subject to quantity.

SC series – primary seals are black as standard, special colours available subject to quantity.

Key for diagrams

- A. Fixing to suit substrate (by others), please refer to Product Data Sheet
- B. Continuous extruded aluminium wall frame
- C. C/S TPR gasket
- D. Stainless steel channel turnbar assembly @ 450mm centres
- E. Factory formed aluminium panel
- F. Continuous extruded aluminium turnbar retainer
- G. Continuous extruded aluminium panel frame
- H. Continuous extruded flexible primary seal
- I. Continuous extruded PVC secondary seal
- J. Continuous extruded aluminium side frame
- K. Continuous butyl tape

SGW-500. Large Span wall-to-wall joint cover.

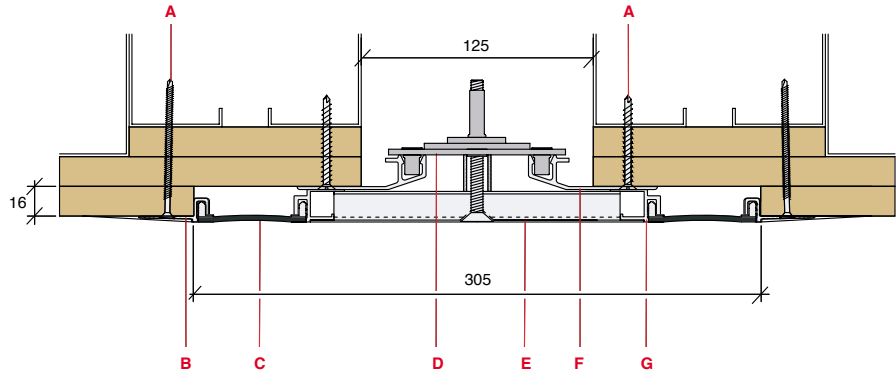

SC-200. Large Span exterior wall-to-wall joint cover.

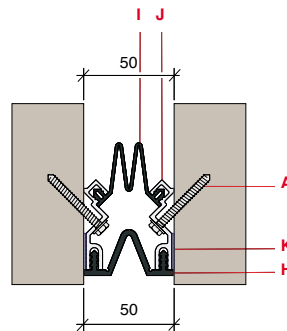

Product Data

Model	Number	Joint Width (mm)	Exposed Surface (mm)	Thermal Movement Capacity ±(mm)			Complementary Floor Joint Covers
				Horizontal	Vertical	Lateral	
SGW*	500	125.0	305.0	±25.0	0	±6.0	SGR-500 or SGP-500
	600	150.0	330.0	±25.0	0	±6.0	SGR-600 or SGP-600
	700	175.0	381.0	±25.0	0	±6.0	SGR-700 or SGP-700
	800	200.0	406.0	±25.0	0	±6.0	SGR-800 or SGP-800
	900	225.0	457.0	±25.0	0	±6.0	SGR-900 or SGP-900
	1000	250.0	483.0	±25.0	0	±6.0	SGR-1000 or SGP-1000
SGWC*	500	125.0	216.0	±12.0	0	±6.0	SGRW-500 or SGPW-500
	600	150.0	241.0	±12.0	0	±6.0	SGRW-600 or SGPW-600
	700	175.0	279.0	±12.0	0	±6.0	SGRW-700 or SGPW-700
	800	200.0	305.0	±12.0	0	±6.0	SGRW-800 or SGPW-800
	900	225.0	343.0	±12.0	0	±6.0	SGRW-900 or SGPW-900
	1000	250.0	368.0	±12.0	0	±6.0	SGRW-1000 or SGPW-1000
SC*	200	50.0	50.0	±25.0	0	0	N/A
	300	75.0	75.0	±50.0	0	0	N/A
	400	100.0	100.0	±75.0	0	0	N/A
	500	125.0	125.0	±100.0	0	0	N/A
	600	150.0	150.0	±125.0	0	0	N/A
	700	175.0	175.0	±150.0	0	0	N/A
	800	200.0	200.0	±175.0	0	0	N/A
	900	225.0	225.0	±200.0	0	0	N/A
	1000	250.0	250.0	±225.0	0	0	N/A

SGW(C) joints can be used in seismic areas.

* Larger sizes available. For details contact our Technical Department on 01296 611000

C/S Allway® Expansion Joint Covers

Plugging Sections for Walls (Interior/Exterior Joints to 66mm)

JD series of flexible wall plugging sections is made of extruded synthetic rubber and is suitable for both interior and exterior applications.

Colours

Black as standard, models JD16-JD42 also available in Grey and Sand.

Product Range

JD-16

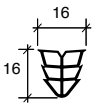

JD-18

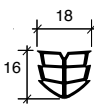

JD-25

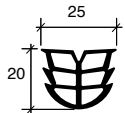

JD-34

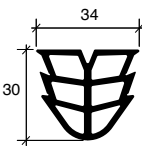

JD-42

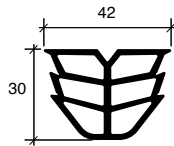

JD-63

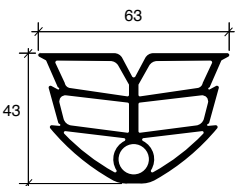

JD-83

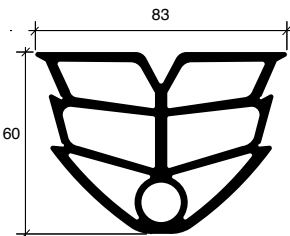

Specification style

Supply and install 120 metres of C/S Allway wall plugging sections, model ref: JD-25 in Black.

All manufactured and supplied by Construction Specialties (UK) Ltd, Conspec House, St Andrews Way, Bicester Road, Aylesbury, Bucks HP19 8AF.
Tel: 01296 611000

Typical Application.

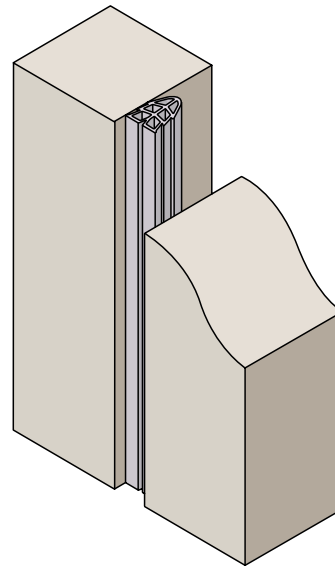

Simple Installation

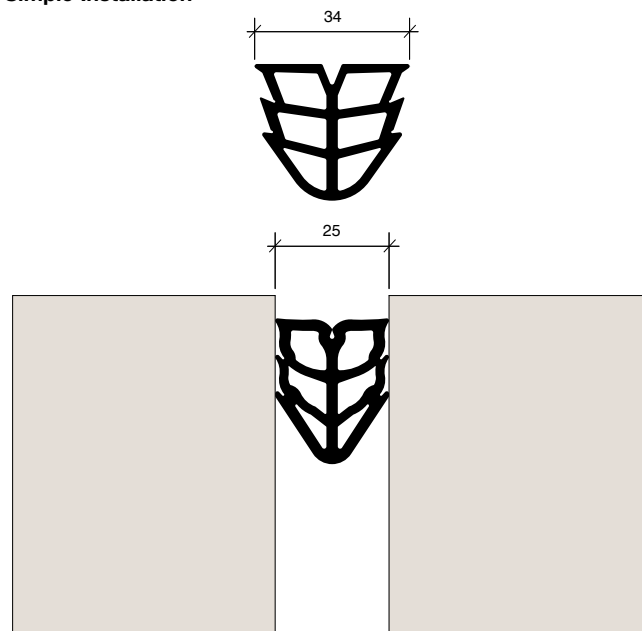

Product Data

Model	Joint Width (mm)	Horizontal movement capacity ±(mm)	Minimum Joint Depth (mm)	Packaging (m)
JD-16	10.0	±2.0	25.0	50.0
JD-18	13.0	±2.0	25.0	50.0
JD-25	18.0	±3.0	30.0	50.0
JD-34	25.0	±3.0	40.0	25.0
JD-42	30.0	±4.0	45.0	25.0
JD-63	50.0	±5.0	70.0	25.0
JD-83	66.0	±6.0	90.0	25.0

C/S Allway® Expansion Joint Covers

Rigid Joint Strips for Walls and Floors (Interior Joints to 100mm)

W series of rigid strips is an attractive and easy-to-fix system for covering wall and floor joints.

Rigid strips are available in:

- Aluminium Alloy 6060 T5; clear anodised as standard (powder-coated upon request)
- PVC: compound suitable for outside use.
Available colours: White, Grey, Sand and Brown.
- Brass: CuZn40Pb 1 Al alloy, polished.

Joint strips are supplied in 3 metre unit lengths as standard with all the necessary fastening accessories.

Fastening using stainless steel clips, with an exception of models W120, W140 and W160, which should be fixed with screws and plugs.

Rigid Joint Strip

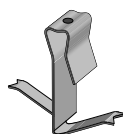
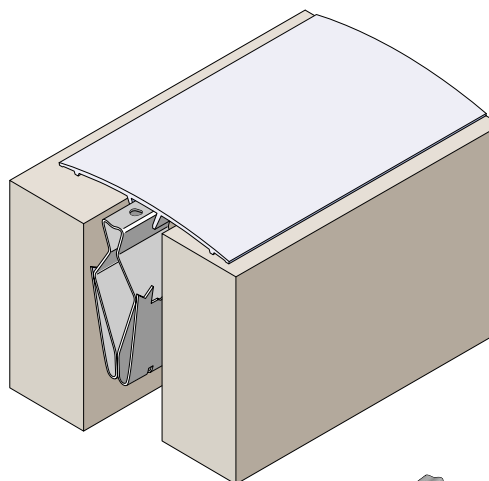

Clip 15-35 for joints 15 to 35mm wide with minimum depth of 40mm

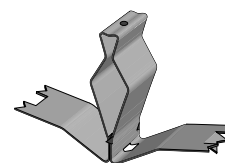

Clip 35-80 for joints 35 to 80mm wide with minimum depth of 60mm

Application	Joint Width Range (mm) min-max	Model	Aluminium	PVC
Flat Wall	up to 15.0	W30		
Flat Wall	15.0-35.0	W5		
Flat Wall or Floor	35.0-50.0	W70		
Flat Wall or Floor	35.0-70.0	W90		
Flat Wall or Floor	35.0-80.0	W120		
Flat Wall	35.0-100.0	W140		
Flat Floor	35.0-80.0	W160		
Corner Wall	15.0-30.0	W50A		
Corner Wall or Corner Floor	35.0-45.0	W70A		
Corner Wall or Corner Floor	40.0-60.0	W90A		

* Brass versions available

** Suitable for corner wall applications only

C/S Allway® Expansion Joint Covers

Fire Barriers

Fire is an ever-present danger. The 'chimney effect' created by an unprotected expansion joint may actually advance its spread.

Construction Specialties' two fire barrier systems are available to cover all building regulation requirements, whilst ensuring that performance is maintained during any building movement.

C/S Reflex Fire Barrier Systems

- Suitable for floors and walls
- Floor joint widths 25-100mm
- Wall joint widths 25-50mm
- BS 476: Part 20: 1987 tested
- ANSI/UL 2079 and ASTM E1966 tested for a 2-hour rating

C/S Reflex Fire Barriers utilize pre-engineered, fibreglass composite insulation assemblies and stainless steel foil heat shields. The wall systems are applicable to both drywall/stud and masonry wall conditions.

Each Reflex system has met ANSI/UL 2079 and ASTM E1966 testing requirements for a 2-hour rating including cycling capabilities of $\pm 50\%$ horizontal movement. Lateral shear movement of $\pm 25\%$ can also be accommodated.

C/S Multiflex Fire Barrier Systems

- Suitable for floors and walls
- Floor and wall joint widths 25-500mm
- BS 476: Part 20: 1987 tested
- ANSI/UL 2079 and ASTM E1966 tested for a 1-hour and 2-hour rating

These systems utilize pre-engineered, ceramic blankets, ceramic papers, stainless foil and screen. Each Multiflex System has met ANSI/UL 2079 and ASTM E1966 testing requirements for a 1-hour and 2-hour rating including cycling capabilities of $\pm 50\%$ horizontal movement. Lateral shear

GFT-200/20. Thinline Flush Seal™ floor joint cover with reflex fire barrier to suit 50mm joint width.

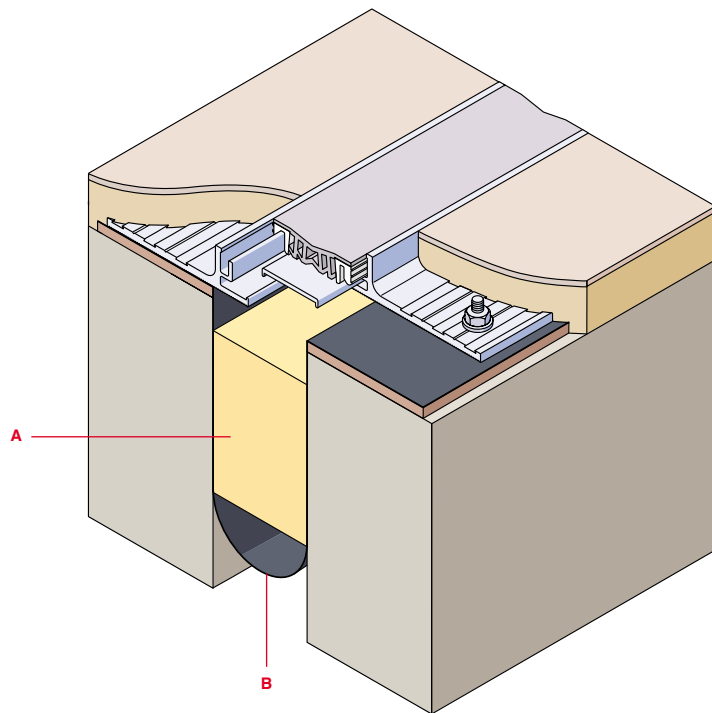

movement of $\pm 50\%$ can also be accommodated, along with a vertical deflection of $\pm 50\text{mm}$.

C/S Fire Barrier systems can be installed more easily and in much less time than most conventional fire barrier systems. This is due to the simple components that make up the systems, and because no fire caulks or complicated and expensive transition miters are required for installation.

Construction Specialties Fire Barrier Systems have been manufactured and tested to provide optimum fire protection when properly installed in the intended environment.

However, no amount of testing can guarantee a 2-hour rating in every application. For that reason we urge you to contact us direct or to contact your local C/S representative for selection assistance during the initial stages of project development.

BS 476: Part 20: 1987 tested
Underwriters Laboratories Inc
classified



GFT-100/20. Thinline Flush Seal™ floor joint cover with Reflex Fire Barrier to suit 25mm joint width.

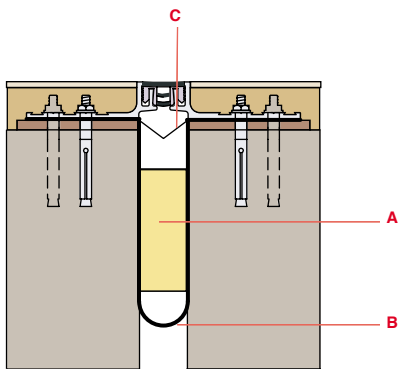

ALXW-200. All Metal™ floor to wall joint cover with Reflex Fire Barrier to suit 50mm joint width.

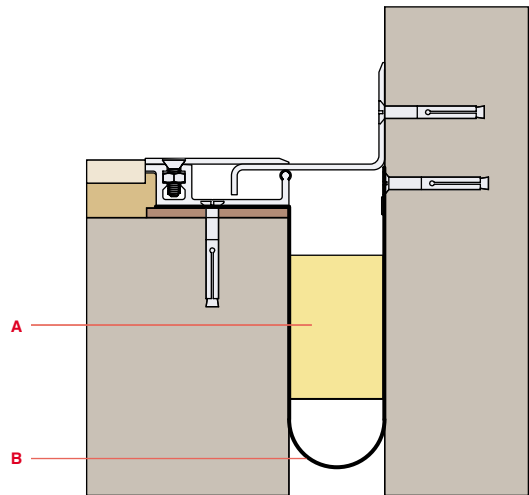

SJP-400. All Metal™ Large Span floor joint cover with Multiflex Fire Barrier to suit 100mm joint width.

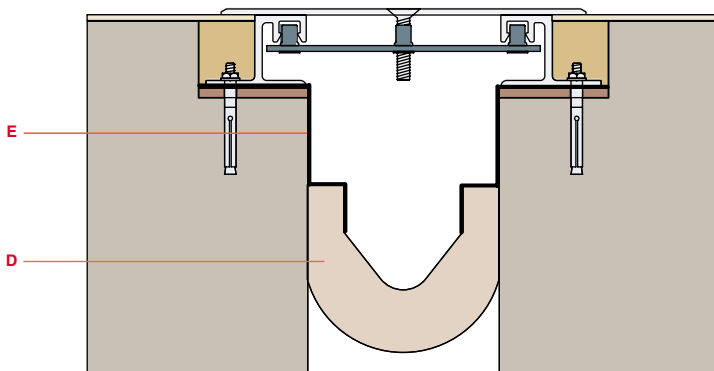

Key for diagrams

- A. Reflex Fire Barrier insulation
- B. Stainless steel heat shield
- C. Stainless steel fire barrier cover (required at chase areas i.e. no expansion joint cover, or behind covers that have gaskets or seals over fire barriers).
- D. Multiflex Fire Barrier
- E. Surface mounted flange

C/S Allway® Technical Information

Loading

With the exception of heavy duty models and some parking deck covers (for point loads up to 907kgs) all joints are typically designed to withstand normal pedestrian traffic (for loads up to 227kgs). For any other loading requirement we strongly recommend consultation with our Technical Department. Installation must be in accordance with the instructions supplied with materials.

C/S TPR (Thermoplastic Rubber)

Gasket - Physical Properties

Brittle Temperature: -39.5°C

Flame Test: Self Extinguishing

For information on C/S TPR Gasket's chemical resistance please contact us on 01296 611000.

Installation recommendations

Bedding

It is normally necessary to apply non-shrink, self-levelling bedding compound on top of concrete floor slabs in order to provide a level, even and structurally sound base over the entire width and length of the expansion joint cover base frame.

Fixings

Fixings for any expansion joint cover system will inevitably tend to be close to the edge of the concrete floor slab. It is therefore essential that any fixings used should not exert an excessive sideways force, which might fracture the concrete along the side of the floor slab.

Production Design

The company reserve the right to make design changes for the purpose of product improvement, or to withdraw any design without notice.



Stock

Stock is held in lengths of 3metres. Custom lengths are available to special order. To check stock please call 01296 611000.

Colours

Aluminium sections are supplied mill finished as standard, with the exception of exposed aluminium covers and frames which are generally supplied clear anodised.

Coloured anodising or powder coating is available as special option, subject to minimum quantity.

Stainless steel sections are supplied dull polished as standard.

Standard C/S TPR Gaskets are available in:

Black White Grey Greige.



Samples

Available from your local C/S representative or C/S direct.

C/S Advisory Service

Construction Specialties representatives are fully trained and experienced in all aspects of

specification and installation and can offer expert advice if required.

Warranty Policy

Construction Specialties (UK) Ltd (the Company) warrants to its customers that all expansion joint covers sold by it will be free from any defects in materials and workmanship and will meet the design criteria noted in our detail manual when properly applied and installed. If, in the sole opinion of the company, a product covered by this warranty is defective the company will replace or repair it free of charge. This warranty shall extend for a period of one year following the date of shipment by the company. This is in lieu of all other warranties expressed or implied and is the sole warranty extended by the company. The liability of the company under this warranty is limited to repair or replacement and does not include any responsibility for consequential or other damage of any nature.

C/S Allway® UK and Global Projects

National Physical Laboratory – Teddington, UK
 Canary Wharf – various projects, London, UK
 Printworks – Manchester, UK
 Stansted Airport – Stansted, UK
 Edinburgh Royal Infirmary – Edinburgh, UK
 Tate Modern – London, UK
 Law Hospital – Wishaw, UK
 Bird in Bush Community Centre – London, UK
 Pfizer – Sandwich, UK
 South Tees Acute Hospital – Middlesbrough, UK
 Cribbs Causeway Shopping Centre – Bristol, UK
 Hexham General Hospital – Hexham, UK
 Larbert High School – Larbert, UK
 Royal Mail - Poole & Bournemouth, UK
 Birmingham International Airport – Birmingham, UK
 Castlepoint Shopping Centre – Bournemouth, UK
 Millennium Pharmaceuticals – Cambridge, UK
 Harvey Nichols – Arndale Centre – Manchester, UK
 Williams Grand Prix Engineering – Wantage, UK
 Chelsea Bridge Wharf – London, UK
 BNFL Sellafield – Seascale, UK
 Great Northern Experience – Manchester, UK
 Elan Pharmaceuticals – Athlone, Ireland
 Cork University Hospital – Ireland
 Wyeth Medica – Newbridge, Ireland
 James Connolly Memorial Hospital – Blanchardstown, Ireland
 Naas General Hospital – Naas, Ireland
 Liffey Valley Shopping Centre – Dublin, Ireland
 JFK Airport Terminal 4 – New York, NY, USA
 San Francisco International Airport – CA, USA
 Mayo Clinic – Rochester, MN, USA
 Chek Lap Kok International Airport – Hong Kong, China
 Incheon International Airport – Seoul, Korea
 University of Cyprus – Cyprus
 Delhi Metro Stations – New Delhi, India
 Mubarak Hospital – Kuwait City, Kuwait
 Khalifa Sports Stadium – Doha, Qatar
 Dubai World Trade Centre Hotel – Dubai, UAE
 Conference Palace Hotel – Abu Dhabi, UAE
 King Fahd International Airport – Dammam, Saudi Arabia
 Prince Sultan City – Riyadh, Saudi Arabia

C/S Group® Other Products

C/S Acrovyn®
Wall, Door and Corner Protection



C/S Supertrak®
Cubicle Curtain Tracking



C/S Wallglaze®
Performance Coatings



C/S Pedisystems®
Entrance Flooring Systems



C/S Airfoil®
Solar Protection Systems



C/S Explovent®
Explosion Venting Systems



C/S Allway® Expansion Joint Covers

United Kingdom

Construction Specialties (UK) Ltd

Conspec House, St Andrews Way,
Bicester Road, Aylesbury, Bucks HP19 8AF

Telephone (+44) 1296 611000

Fax (+44) 1296 399444

Email allway@c-sgroup.co.uk

Website www.c-sgroup.co.uk

Middle East

Construction Specialties Middle East L.L.C.

1705 Dubai World Trade Centre

PO Box 9260, Dubai, UAE

Telephone (+971 4) 331 2167

(+971 4) 331 1673

Fax (+971 4) 331 5023

Email cs_dubai@emirates.net.ae

Website www.c-sgroup.com

Singapore

Conspec (Singapore) Pte. Ltd

298 Tiong Bahru Road, #13-01 Central Plaza,

Singapore 168730

Telephone (+65) 6 276 4276

Fax (+65) 6 273 7557

Email solutions@c-sgroup.com.sg

Website www.c-sgroup.com.sg

Brazil

C/S Group do Brazil

Av. Vereador João de Luca, 1220

Jardim Prudência, SP 04381-000, São Paulo

Telephone (+55) 11 5677 5279

(+55) 11 5677 3089

Fax (+55) 11 5679 5084

Email marianopache@uol.com.br

Website www.c-sgroup.com

Australia

Construction Specialties Australia PTY Ltd

A7/1 Endeavour Road, Caringbah NSW 2229

PO Box 51, Cronulla NSW 2230

Telephone (+61) 2 9540 5400

Fax (+61) 2 9540 5253

Email sales@c-sgroup.com.au

Website www.c-sgroup.com.au



BS EN ISO 9001: 2000
Certificate No FM21206

C/S GROUP Worldwide operations

- United Kingdom
- France
- Germany
- Austria
- Italy
- Spain
- Poland
- USA
- Canada
- Australia
- New Zealand
- Singapore
- Hong Kong
- Taiwan
- UAE
- Uruguay